

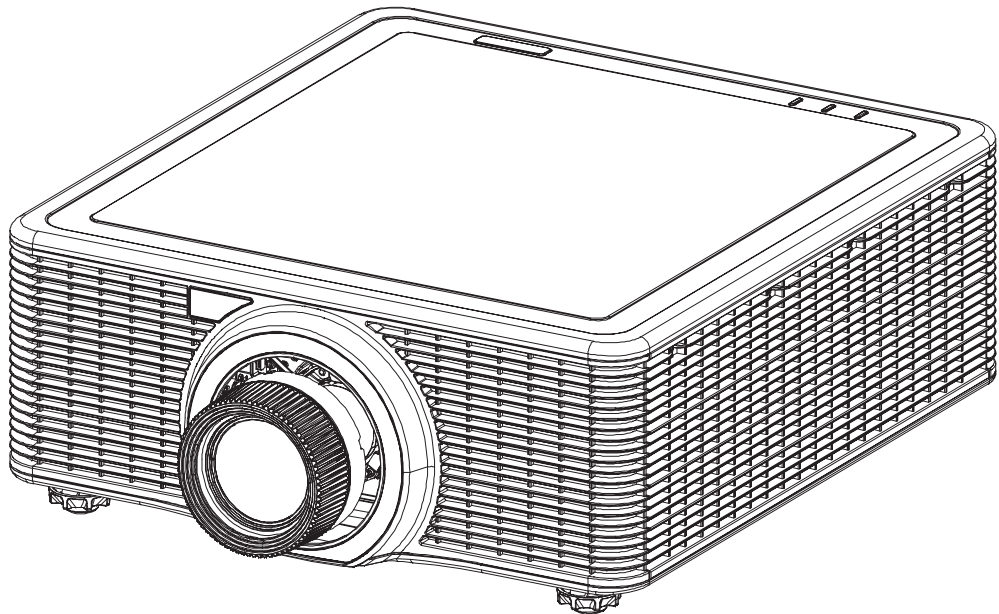

Owner's Manual



Multimedia Projector

Model EK-812U/EK-818U
(Projection lens is optional.)

Features and Design

This Multimedia Projector is designed with the most advanced technology for portability, durability, and ease of use. This projector utilizes a high luminance and Eco friendly system, a palette of 1.07 billion colors, and digital light processing (DLP) technology.

Simple Computer System Setting

The projector has the Multi-scan system to conform to almost all computer output signals quickly. Up to WUXGA resolution can be accepted.

Useful Functions for Presentations

The power zoom function allows you to focus on the crucial information during a presentation.

Laser Diode Control

Brightness of the projection laser diode can be manually selected (Constant Power, Constant Luminance, or Eco Mode).

Background Color Function

The Background Color function allows you to specify the screen background (“Logo”, “Blue”, “Black”, or “White” screen) when no signal is available.

Multilanguage Menu Display

Operation menu is available in 13 languages; English, French, Spanish, German, Italian, Russian, Simplified Chinese, Japanese, Korean, Portuguese, Indonesian, Dutch, and Arabic.

Security Function

The Security function helps you ensure security of the projector.

LAN Network Function

This projector is loaded with the Wired LAN network function. You can operate and manage the projector via network.

For details, refer to pages 41-42 and 45-51.

Auto Source Function

This function enables auto input search and auto signal adjustment simply by pressing the Auto button on the remote control.

Power Management

The Power management function reduces power consumption and maintains the laser diode life.

4K Compatible

This projector supports HDMI 2.0, which plays true 4K videos at 50 and 60 frames per second, without any compromise on the image quality.

For details, refer to page 38.

HDR (High Dynamic Range)

This projector is compatible with HDR content. HDR allows the projector to show image with higher dynamic range, expanding the range of contrast ratio and color for a more natural and realistic image.

Note:

*The screen menu and pictures in the manual may slightly differ from the real product.
The manual is subject to change without prior notice.*

Copyright

This publication, including all photographs, illustrations and software, is protected under international copyright laws, with all rights reserved. Neither this manual, nor any of the material contained herein, may be reproduced without written consent of the author.

© Copyright 2019

Disclaimer

The information in this document is subject to change without notice. The manufacturer makes no representations or warranties with respect to the contents hereof and specifically disclaims any implied warranties of merchantability or fitness for any particular purpose. The manufacturer reserves the right to revise this publication and to make changes from time to time in the content hereof without obligation of the manufacturer to notify any person of such revision or changes.

Trademark Recognition

All other product names used in this manual are the properties of their respective owners and are acknowledged.

Important Safety Information

Important:

It is strongly recommended that you read this section carefully before using the projector. These safety and usage instructions will ensure that you enjoy many years of safe use of the projector. Keep this manual for future reference.

Symbols Used

Warning symbols are used on the unit and in this manual to alert you of hazardous situations. The following styles are used in this manual to alert you to important information.

Note:

Provides additional information on the topic at hand.

Important:

Provides additional information that should not be overlooked.

Caution:

Alerts you to situations that may damage the unit.

Warning:

Alerts you to situations that may damage the unit, create a hazardous environment, or cause personal injury.

Throughout this manual, component parts and items in the OSD menus are denoted in bold font as in this example:

“Push the **Menu** button on the remote control to open the **Main** menu.”

General Safety Information

- Do not open the unit case. There are no user-serviceable parts in the unit. For servicing, contact qualified service personnel.
- Follow all warnings and cautions in this manual and on the unit case.
- The projection laser diode is extremely bright by design. To avoid damage to eyes, do not look into the lens when the laser diode is on.
- Do not place the unit on an unstable surface, cart, or stand.
- Avoid using the system near water, in direct sunlight, or near a heating device.
- Do not place heavy objects such as books or bags on the unit.

Safety Instructions

- Please read this manual completely before installing and operating the projector.
- The projector provides many convenient features and functions. Proper operation may enable you to fully utilize the features and keep it in good condition. Otherwise, it will not only shorten the service life of the unit, but also may cause malfunction, a fire, or other accidents.
- If your projector cannot work properly, please read this manual again, check the operating methods and cable connection, and try the solutions in the part of Troubleshooting. If the problem still exists, contact the dealer or the service center.

Caution:



ELECTRIC SHOCK DO NOT OPEN



Caution:

To reduce the risk of electric shock, do not remove cover (or back), no user serviceable parts inside. Refer servicing to qualified service personnel.



This symbol indicates that dangerous voltage constituting a risk of electric shock is present within this unit.



This symbol indicates that there are important operating and maintenance instructions in the user's manual with this unit.

FOR EU USERS

The symbol mark and recycling systems described below apply to EU countries and do not apply to countries in other areas of the world.

Your product is designed and manufactured with high quality materials and components which can be recycled and/or reused.

The symbol mark means that electrical and electronic equipment, batteries and accumulators, at their end-of-life, should be disposed of separately from your household waste.

Note:

If a chemical symbol is printed beneath the symbol mark, this chemical symbol means that the battery or accumulator contains a heavy metal at a certain concentration. This will be indicated as follows: Hg: mercury, Cd: cadmium, Pb: lead In the European Union there are separate collection systems for used electrical and electronic equipment, batteries and accumulators. Please, dispose of them correctly at your local community waste collection/recycling centre. Please help us to conserve the environment we live in!





Safety Precautions

Caution:

- *The projector must be grounded.*
- *Do not expose the projector to raindrops or high humidity to avoid a fire or electric shock.*

- This projector produces intense light from the projection lens. Avoid staring directly into the lens, otherwise eye damage could be caused. Be especially careful that children do not stare directly into the beam.
- Place the projector in a proper position. Otherwise it may result in fire hazard.
- Leave an appropriate space from the top, sides, and back of the shell in order to ventilate and cool down the projector. The figures below indicate the minimum distance to be left. It must be satisfied if the projector is placed in sealed environment like a cabinet.

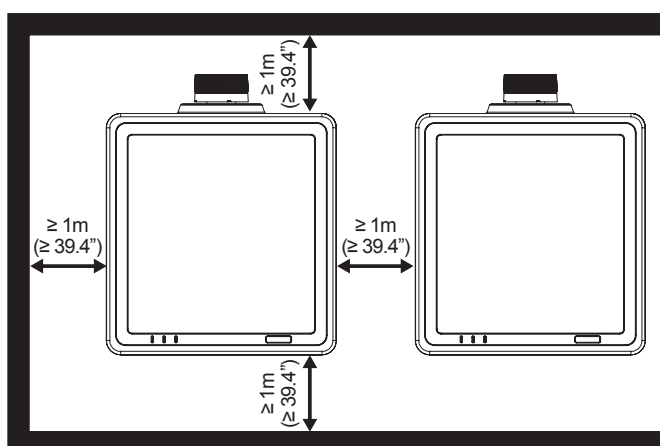

- Do not cover the vent of the projector. Poor radiation may shorten the service life or even cause dangers.
- Remove the AC power plug if the projector is not to be used for a long time.

**Caution:**

- *Do not set the projector in greasy, wet, or smoky conditions such as in a kitchen, to prevent a malfunction or accident. If the projector comes in contact with oil or chemicals, it may become deteriorated.*
- *Read and keep this manual for future reference.*
- *The mains plug/appliance coupler is used as disconnect device, the disconnect device shall remain readily operable.*

Safety Guide

- All the safety and operating instructions should be read before the product is operated.
 - Read all of the instructions given here and retain them for later use. Unplug this projector from AC power supply before cleaning. Do not use liquid or aerosol cleaners.
 - Use a damp cloth for cleaning.
 - Follow all warnings and instructions marked on the projector.
 - For added protection to the projector during a lightning storm, or when it is left unattended and unused for long periods of time, unplug it from the wall outlet. This will prevent damage due to lightning and power line surges.
 - Do not expose this unit to rain or use near water, for example, in a wet basement, near a swimming pool, etc.
 - Do not use attachments not recommended by the manufacturer as they may cause hazards.
 - Do not place this projector on an unstable cart, stand, or table. The projector may fall, causing serious injury to a child or an adult, and serious damage to the projector.
- 
- Use only with a cart or stand recommended by the manufacturer, or sold with the projector. Wall or shelf mounting should follow the manufacturer's instructions, and should use a mounting kit approved by the manufacturers.
 - An appliance and cart combination should be moved with care. Quick stops, excessive force, and uneven surfaces may cause the appliance and cart combination to overturn.
 - Slots and openings in the back and bottom of the cabinet are provided for ventilation, to ensure reliable operation of the equipment and to protect it from overheating.
 - The openings should never be covered with cloth or other materials, and the bottom opening should not be blocked by placing the projector on a bed, sofa, rug, or other similar surface. This projector should never be placed near or over a radiator or heat register.
 - This projector should not be placed in a build-in installation such as a book case unless proper ventilation is provided.
 - Never push objects of any kind into this projector through cabinet slots as they may touch dangerous voltage points or short out parts that could result in a fire or electric shock. Never spill liquid of any kind on the projector.
 - Do not install the projector near the ventilation duct of air-conditioning equipment.
 - This projector should be operated only from the type of power source indicated on the marking label.
 - If you are not sure of the type of power supplied, consult your authorized dealer or local power company.
 - Do not overload wall outlets and extension cords as this can result in fire or electric shock. Do not allow anything to rest on the power cord. Do not locate this projector where the cord may be damaged by persons walking on it.
 - Do not attempt to service this projector yourself as opening or removing the covers may expose you to dangerous voltage or other hazards. Refer all servicing to qualified service personnel.
 - Unplug this projector from wall outlet and refer servicing to qualified service personnel under the following conditions:
 - When the power cord or plug is damaged or frayed.
 - If liquid has been spilled into the projector.
 - If the projector has been exposed to rain or water.
 - If the projector does not operate normally by following the operating instructions. Adjust only those controls that are covered by the operating instructions as improper adjustment of other controls may result in damage and will often require extensive work by a qualified technician to restore the projector to normal operation.
 - If the projector has been dropped or the cabinet has been damaged.

- When the projector exhibits a distinct change in performance - this indicates a need for service.
- When replacement parts are required, be sure the service technician has used replacement parts specified by the manufacturer that have the same characteristics as the original part. Unauthorized substitutions may result in fire, electric shock, or injury to persons.
- Upon completion of any service or repairs to this projector, ask the service technician to perform routine safety checks to determine that the projector is in safe operating condition.

Information for users in the European Union

This is a device to project images onto a screen, etc., and is not intended for use as indoor lighting in a domestic environment.

Directive 2009/125/EC.

Warning:

Do not aim a laser pointer at the lens aperture, which may damage the DMD in the projector and cause personal injury.

We are not responsible for the hurt and damage caused by the improper use of laser pointer even in warranty period.

Air circulation

Vents in the cabinet are provided for ventilation. To ensure reliable operation of the product and to protect it from overheating, these openings must not be blocked or covered.



Caution:

- *Hot air is exhausted from the exhaust vent. When using or installing the projector, the following precautions should be taken.*
- *Do not put any flammable objects, or spray can near the projector. Hot air is exhausted from the air vents.*
- *Keep the exhaust vent at least 1m away from any objects.*
- *Do not touch a peripheral part of the exhaust vent, especially screws and metallic part. This area will become hot while the projector is being used.*
- *Do not put anything on the projector. Objects put on the cabinet will not only get damaged but also may cause fire hazard by heat.*
- *Cooling fans are provided to cool down the projector.*
- *The fan's running speed is changed according to the temperature inside the projector.*

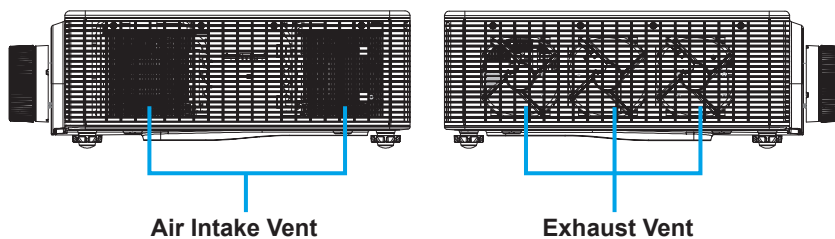

Moving the projector

When moving the projector, take care of the lens and retract the adjustable foot to prevent damage to the lens and cabinet.



Caution in moving or transporting the projector

- Do not drop or bump the projector, otherwise damages or malfunctions may result.
- When carrying the projector, use a suitable carrying case.
- Do not transport the projector by courier or any other transport service in an unsuitable transport case. This may cause damage to the projector. For information about transporting the projector by courier or any other transport service, consult your dealer.

Installing the projector properly

- Please set the projector on nearly-level.
- Be sure to install the projector properly. Improper installation may reduce the laser diode lifetime and even cause a fire hazard.
- 360 degree free orientation operation.

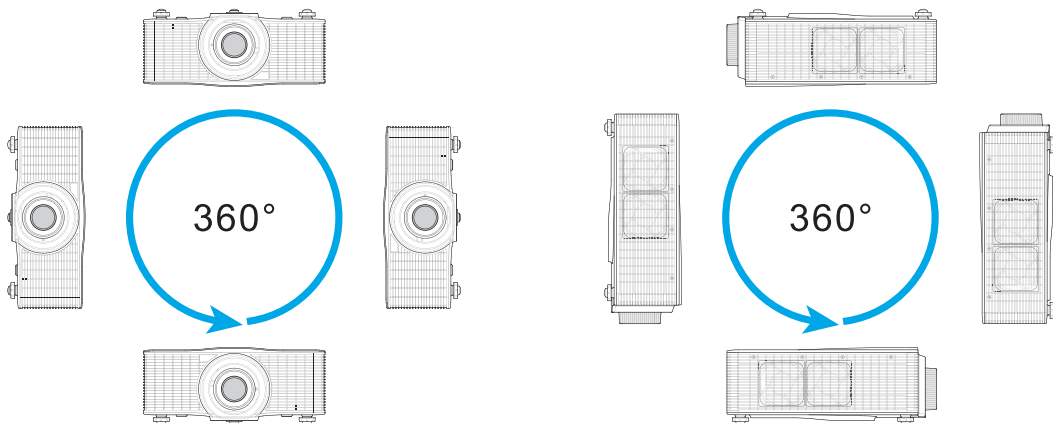

- When installing multiple projectors, keep at least 1 cm (39.4") space between the adjacent projectors.

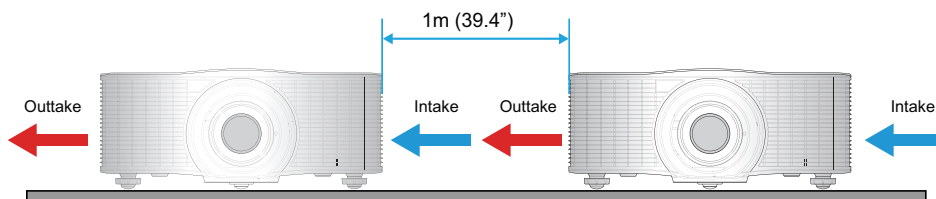

- For ceiling mount installations, make sure to leave 30 mm (1.2") between the ceiling mount and the bottom intake vents of the projector.

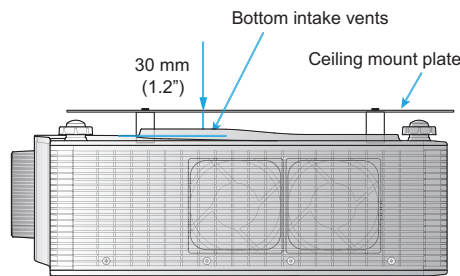

- Please ensure the screws used to attach a mount to the projector meet the specifications: M6x4, 10mm.

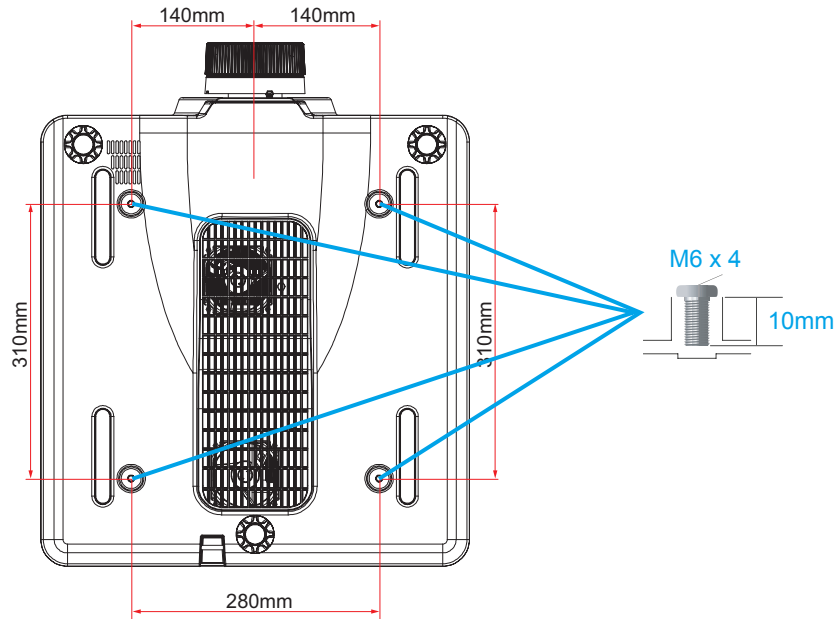

Caution in ceiling installation the projector

- Only qualified personal is authorized for ceiling installation.
- We are not responsible for the hurt and damage caused by ceiling bracket that purchased from unauthorized dealer even in warranty period.
- Remove the ceiling bracket immediately while not use.
- While installing, torque screwdriver is suggested, don't use electric or impact-type screwdriver.
- Please read the manual of bracket for details.
- The bracket is subject to change without notice.

Important Information

Laser Safety Cautions

This product is classified as CLASS 1 LASER PRODUCT - RISK GROUP 2 of IEC 60825-1:2014 and also complies with 21 CFR 1040.10 and 1040.11 except for conformance as a Risk Group 2 LIP as defined in IEC 62471-5:Ed. 1.0. For more information see Laser Notice No. 57, dated May 8, 2019.

	<p>IEC/EN 60825-1:2014 CLASS 1 LASER PRODUCT RISK GROUP 2 Complies with 21 CFR 1040.10 and 1040.11 except for conformance as a Risk Group 2 LIP as defined in IEC 62471-5:Ed. 1.0. For more information see Laser Notice No. 57, dated May 8, 2019.</p>
	<p>IEC/EN 60825-1:2014 PRODUIT LASER DE CLASSE 1 GROUPE DE RISQUE 2 Conforme aux normes 21 CFR 1040.10 et 1040.11, à l'exception de la conformité en tant que LIP du groupe de risque 2 définie dans la CEI 62471-5: Ed. 1,0. Pour plus d'informations, voir l'avis au laser n° 57 du 8 mai 2019.</p>
	<p>IEC/EN 60825-1:2014 1類激光產品RG2危險等級 除了IEC 62471-5:Ed.1.0中定義的RG2 LIP 危險等級以外，要符合21 CFR 1040.10和1040.11，更多相關資訊，請參閱2019年5月8日的第57號激光公告。</p>
	<p>IEC/EN 60825-1:2014 1类激光产品RG2危险等级 除了IEC 62471-5:Ed.1.0中定义的RG2 LIP 危险等级以外，要符合21 CFR 1040.10和1040.11，更多相关信息，请参阅2019年5月8日的第57号激光公告。</p>

- This projector has built-in Class 4 laser module. Disassembly or modification is very dangerous and should never be attempted.
- Any operation or adjustment not specifically instructed in the user's guide creates the risk of hazardous laser radiation exposure.
- Do not open or disassemble the projector as this may cause damage by the exposure of laser radiation.
- Do not stare into beam when the projector is on. The bright light may result in permanent eye damage.
- When turning on the projector, make sure no one within projection range is looking at the lens.
- Without following the control, adjustment or operation procedure may cause damage by the exposure of laser radiation.
- Adequate instructions for the assembly, operation, and maintenance, including clear warnings concerning precautions to avoid possible exposure to laser.
- IEC 60825-1: 2014 Class 1 RG2
- IEC 62471-5:2015 RG2
- Additional instructions to supervise children, no staring, and not use optical aids.
- Additional instructions to install above the reach of children.
- Notice is given to supervise children and to never allow them to stare into the projector beam at any distance from the projector.
- Notice is given to use caution when using the remote control for starting the projector while in front of the projection lens.
- Notice is given to the user to avoid the use of optical aids such as binoculars or telescopes inside the beam.
- Do not stare into the beam, RG2.
As with any bright source, do not stare into the beam, RG2 IEC 62471-5:2015.



- “WARNING: MOUNT ABOVE THE HEADS OF CHILDREN.” The use of a ceiling mount is recommended with this product to place it above the eyes of children.

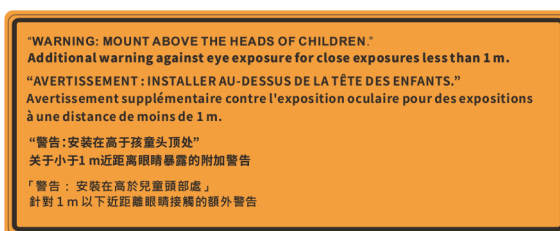

Compliance

FCC Caution

Note: This equipment has been tested and found to comply with the limits for a Class A digital device, pursuant to Part 15 of the FCC Rules. These limits are designed to provide reasonable protection against harmful interference in a residential installation. This equipment generates, uses, and can radiate radio frequency energy, and if not installed and used in accordance with the instructions, may cause harmful interference to radio communications. However, there is no guarantee that interference will not occur in a particular installation. If this equipment does cause harmful interference to radio or television reception, which can be determined by turning the equipment off and on, the user is encouraged to try to correct the interference by one or more of the following measures:

- Reorient or relocate the receiving antenna.
- Increase the separation between the equipment and receiver.
- Connect the equipment into an outlet on a circuit different from that to which the receiver is connected.
- Consult the dealer or an experienced radio/TV technician for help.

Use of shielded cable is required to comply with class A limits in Subpart B of Part 15 of FCC Rules.

Do not make any changes or modifications to the equipment unless otherwise specified in the instructions. If such changes or modifications should be made, you could be required to stop operation of the equipment.

Model Number : EK-812U/EK-818U

Trade Name : EIKI

Responsible party : EIKI International, Inc.

Address : 30251 Esperanza Rancho Santa Margarita CA 92688-2132

Telephone No. : 800-242-3454 (949-457-0200)

Canadian Radio Interference Regulations:

This digital apparatus meets all requirements of the Canadian ICES-003.

**See the rating label on the projector if class A or B.*

Note:

For use in a commercial, industrial or business environment.

Not for domestic use.

AC Power Cord Requirement

The AC Power Cord supplied with this projector meets the requirement for use in the country you purchased it.

AC Power Cord for the United States and Canada:

AC Power Cord used in the United States and Canada is listed by the Underwriters Laboratories (UL) and certified by the Canadian Standard Association (CSA).

AC Power Cord has a grounding-type AC line plug. This is a safety feature to be sure that the plug will fit into the power outlet. Do not try to defeat this safety feature. Should you be unable to insert the plug into the outlet, contact your electrician.

Warning:

A plug with bared flexible cord is hazardous if engaged in a live socket outlet.

The Wires in this mains lead are coloured in accordance with the following code:

- Green-and-yellow Earth
- Blue Neutral
- Brown Live

As the colours of the wires in the mains lead of this apparatus may not correspond with the coloured markings identifying the terminals in your plug proceed as follows:

- The wire which is coloured green-and-yellow must be connected to the terminal in the plug which is marked by the letter E or by the safety earth symbol or coloured green or green-and-yellow.
- The wire which is coloured blue must be connected to the terminal which is marked with the letter N or coloured black.
- The wire which is coloured brown must be connected to the terminal which is marked with the letter L or coloured red.

Warning:

This apparatus must be earthed.

Note:

The socket-outlet should be installed near the equipment and easily accessible.

Contents

GETTING STARTED.....	1
PACKING CHECKLIST.....	1
VIEWS OF PROJECTOR PARTS.....	2
Front-right View	2
Rear View	3
Built-in Keypad.....	4
Bottom View.....	5
REMOTE CONTROL PARTS	6
REMOTE CONTROL OPERATING RANGE.....	8
PROJECTOR AND REMOTE CONTROL BUTTONS.....	8
REMOTE CONTROL CODE.....	8
INSERTING THE REMOTE CONTROL BATTERIES	9
SETUP AND OPERATION	10
INSTALLING THE PROJECTION LENS.....	10
STARTING AND SHUTTING DOWN THE PROJECTOR	12
Turn the Projector On	12
Turn the Projector Off	12
ADJUSTING THE PROJECTOR LEVEL.....	13
ADJUSTING THE ZOOM, FOCUS, AND KEYSTONE	14
USING THE LENS SHIFT ADJUSTMENT	15
Vertical / Horizontal Lens Shift.....	15
OPTIONAL LENSES AND PROJECTION SIZE.....	17
Projection Lens.....	17
Projection Size v.s Throw Distance.....	19
ON-SCREEN DISPLAY (OSD) MENU SETTINGS	20
OSD MENU CONTROLS.....	20
Navigating the OSD.....	20
SETTING THE OSD LANGUAGE	21
OSD MENU OVERVIEW	22
PICTURE MENU	30
3D Display Menu	31
HSG Adjustment Menu	32
Advanced Menu.....	33
OUTPUT MENU	34
Image Warping Menu.....	35
PIP/PBP Menu.....	36

SETUP MENU	38
Lens Function Menu	39
Menu Preferences Menu	40
PIN Menu	40
Communications Menu	41
OPTION MENU	42
Power Settings Menu	43
Light Source Settings Menu	44
CONTROL YOUR PROJECTOR USING WEB BROWSER	45
Wired LAN Terminal functionalities	45
Supported External Devices	45
LAN_RJ45	45
RS232 by Telnet Function	49
MAINTENANCE AND SECURITY	52
REPLACING THE PROJECTION LENS	52
CLEANING THE PROJECTOR	53
Cleaning the Lens	53
Cleaning the Case	53
USING THE KENSINGTON® LOCK	54
TROUBLESHOOTING	55
COMMON PROBLEMS AND SOLUTIONS	55
TIPS FOR TROUBLESHOOTING	55
LED ERROR MESSAGES	56
IMAGE PROBLEMS	57
LASER DIODE PROBLEMS	57
REMOTE CONTROL PROBLEMS	58
HAVING THE PROJECTOR SERVICED	58
HDMI Q & A	59
SPECIFICATIONS	60
SPECIFICATIONS	60
PROJECTION DISTANCE VS. PROJECTION SIZE	61
Projection Distance and Size Table	61
TIMING MODE TABLE	62
PROJECTOR DIMENSIONS	66

REGULATORY COMPLIANCE 67
FCC WARNING 67
CANADA 67
SAFETY CERTIFICATIONS 67

GETTING STARTED

Packing Checklist

Carefully unpack the projector and check that the following items are included:

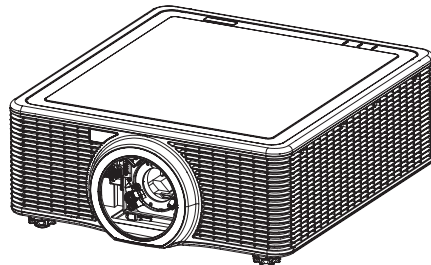

DLP PROJECTOR

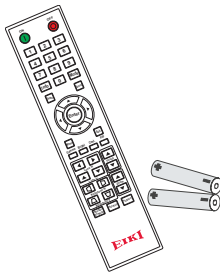

REMOTE CONTROL
(WITH TWO AAA
BATTERIES)

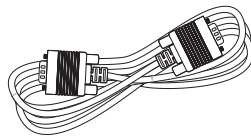

VGA CABLE

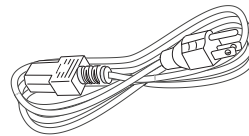

POWER CORD

* For other regions except China:
POWER CORD x 2 (US and EU)
* For China: POWER CORD x 1

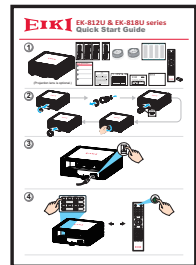

QUICK START GUIDE

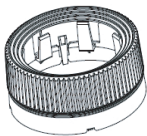

LENS COVER
* For A01, A03, and A13 lens

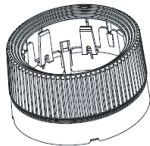

LENS COVER
* For A06 lens



CD-ROM
(THIS OWNER'S MANUAL)
for China



SAFETY GUIDE



WARRANTY CARD
for USA

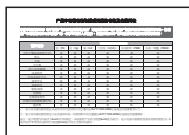

RoHS CARD
for China



QC PASS CARD
for China

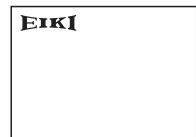

WARRANTY CARD
for China

Contact your dealer immediately if any items are missing, appear damaged, or if the unit does not work. It is recommend that you keep the original packing material should you ever need to return the equipment for warranty service.

Note:

- Avoid using the projector in dusty environments.

Views of Projector Parts

Front-right View

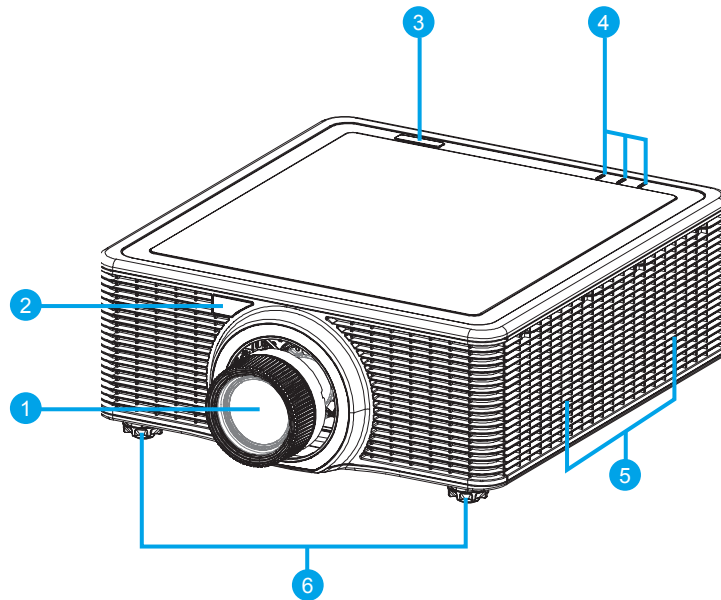

ITEM	LABEL	DESCRIPTION	SEE PAGE
1	Projection Lens	Allows automated lens control and adjustment: vertical and horizontal offsets, zoom and focus.	-
2	Front IR Sensor	Receives signals from the IR remote. Keep the signal path to the sensor unobstructed for uninterrupted communication with the projector.	8
3	Top IR Sensor		
4	LED Status Indicators	Displays the status of the projector.	56
5	Cooling Air Vents (Intake)	Keep these vents unobstructed to prevent the projector from overheating.	-
6	Adjustable Feet	Raise or lower the feet to level the projector.	13

Important:

Ventilation openings on the projector allow for good air circulation, which keeps the projector laser diode cool. Do not obstruct any of the ventilation openings.

Rear View

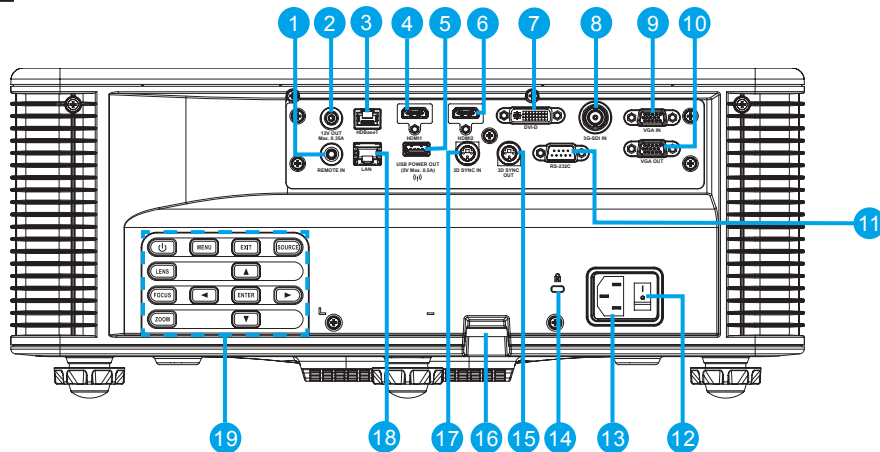

ITEM	LABEL	DESCRIPTION	SEE PAGE
1	REMOTE IN	Connect to the remote control wired terminal for serial control projector.	-
2	12V OUT	Connect to provide 12V DC power to an accessory when the 12V trigger is set to On.	-
3	HDBaseT	Connect a RJ45 Cat5/Cat6 Ethernet cable to input uncompressed high-definition video control signals.	-
4	HDMI1	Connect the HDMI cable from a HDMI device.	-
5	USB POWER OUT	Connect the WIFI dongle.	-
6	HDMI2	Connect the HDMI cable from a HDMI device.	-
7	DVI-D	Connect to DVI source.	-
8	3G-SDI IN	Connect the coaxial cable with BNC connector from a 3G-SDI device.	-
9	VGA IN	Connect the VGA cable from a computer or component device.	-
10	VGA OUT	Connect the VGA cable to a display.	-
11	RS-232C	Connect RS-232C serial port cable for remote control.	-
12	Power Switch	Switch the power button to turn on/off the power source.	12
13	AC Input	Connect to the supplied power adapter.	12
14	Kensington Lock	Use to secure the projector to countertops, tables, etc.	54
15	3D SYNC OUT	Connect the 3D IR glasses transmitter. (Note: For Specific 3D IR glasses only)	-
16	Security Bar	Use to secure the projector.	-
17	3D SYNC IN	Connect to the 3D IR synchronization signal transmitter.	-
18	LAN	Connect a LAN cable from Ethernet.	-
19	Built-in Keypad	Control the projector.	4

Note:

- To use this feature, you must plug in the power adapter/cable/cord before turn on/off the projector.
- Do not use this jack for anything other than intended use.

Warning:

As a safety precaution, disconnect all power to the projector and connecting devices before making connections.

Built-in Keypad

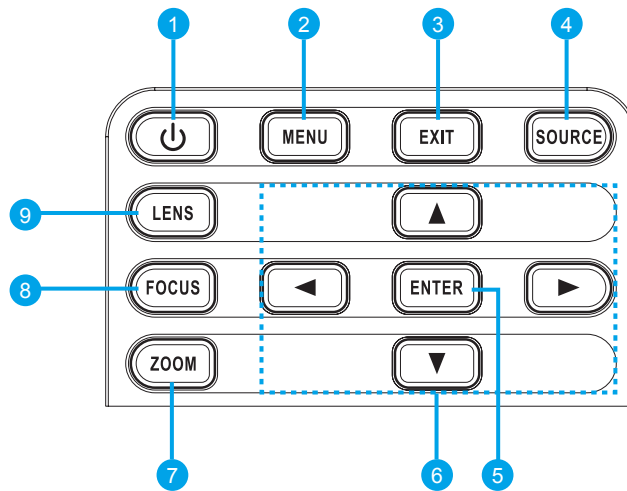

ITEM	LABEL	DESCRIPTION	SEE PAGE
1	Power	Turn the projector on or off.	12
2	Menu	Display menus.	20
3	Exit	Return to previous level or exit menus if at top level.	20
4	Source	Select an input for the main or PIP/PBP image.	-
5	Enter	<ul style="list-style-type: none"> Select a highlighted menu item. Change or accept a value. 	20
6	Arrow keys	<ul style="list-style-type: none"> Adjust a setting UP or DOWN. Navigate within a menu. 	20
7	Zoom	Adjust zoom.	14
8	Focus	Adjust focus.	14
9	Lens	Adjust the lens vertical or horizontal offset setting.	15-18

Bottom View

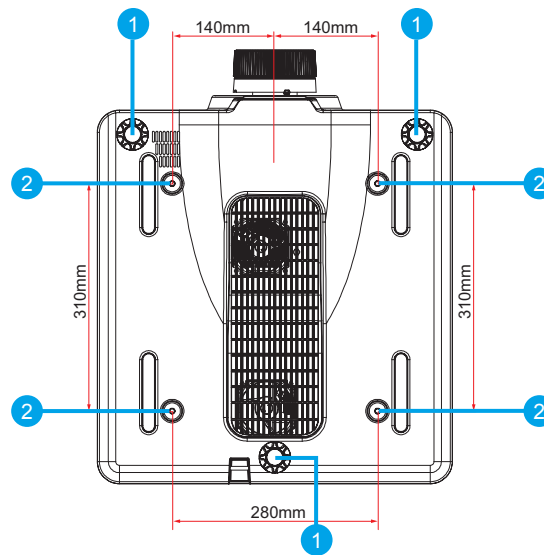

ITEM	LABEL	DESCRIPTION	SEE PAGE
1	Adjustable Feet	Raise or lower the feet to level the projector.	13
2	Ceiling support holes	Contact your dealer for information on mounting the projector on a ceiling.	-

Note:

- When installing, ensure that you use only UL Listed ceiling mounts.
- For ceiling installations, use approved mounting hardware and M6 screws with a maximum screw depth of 10 mm (0.39 inch).
- The construction of the ceiling mount must be of a suitable shape and strength. The ceiling mount load capacity must exceed the weight of the installed equipment, and as an additional precaution be capable of withstanding three times the weight of the equipment (not less than 71.4 kg) over a period of 60 seconds.

Remote Control Parts

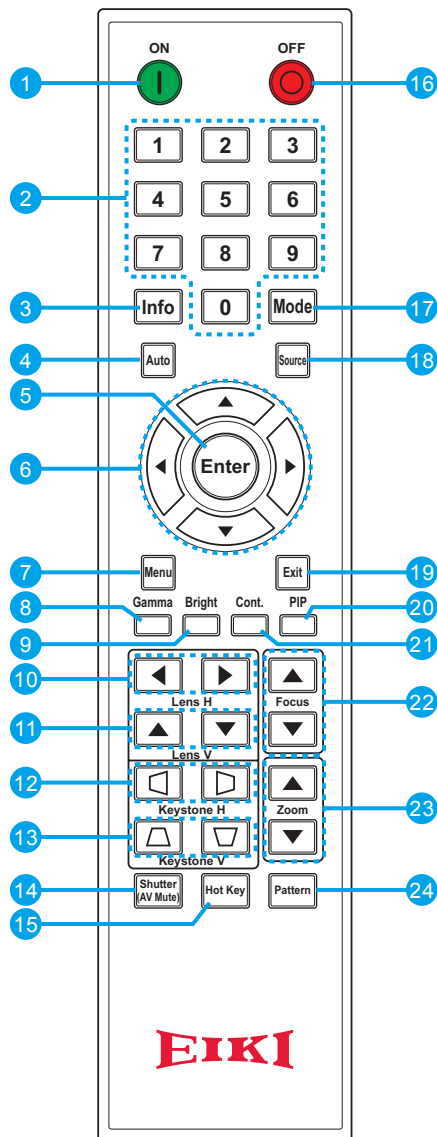

Important:

1. Avoid using the projector with bright fluorescent lighting turned on. Certain high-frequency fluorescent lights can disrupt remote control operation.
2. Be sure nothing obstructs the path between the remote control and the projector. If the path between the remote control and the projector is obstructed, you can bounce the signal off certain reflective surfaces such as projector screens.
3. The buttons and keys on the projector have the same functions as the corresponding buttons on the remote control. This owner's manual describes the functions based on the remote control.

Note:

Complies with FDA performance standards for laser products except for deviations pursuant to Laser Notice No. 50, dated June 24, 2007.

ITEM	LABEL	DESCRIPTION	SEE PAGE
1	Power on	Turn projector ON.	12
2	Number Keys	Enter a number (such as PIN code) or source hotkey. Source Hotkey Key: 1: HDMI 1 2: HDMI 2 3: DVI-D 4: VGA 5: HDBaseT 6: 3G-SDI	-
3	Info	Display image information.	-
4	Auto	Automatically optimize image.	-
5	Enter	<ul style="list-style-type: none"> Select a highlighted menu item. Change or accept a value. 	20
6	Arrow Keys	<ul style="list-style-type: none"> Adjust a setting UP or DOWN. Navigate within a menu. 	20
7	Menu	Display menus.	20
8	Gamma	Adjust mid-range levels.	-
9	Bright	Adjust amount of light in the image.	-
10	Lens H	Adjust the position of the image horizontally.	-
11	Lens V	Adjust the position of the image vertically.	-
12	Keystone H	Adjust the horizontal keystone.	35
13	Keystone V	Adjust the vertical keystone.	35
14	Shutter (AV Mute)	Display or blank the video image.	-
15	Hot Key	Select your preset keys quickly.	-
16	OFF	Turn OFF projector.	12
17	Mode	Select the preset display mode.	-
18	Source	Select an input for the main or PIP/PBP image.	-
19	Exit	Return to previous level or exit menus if at top level.	20
20	PIP	Turn PIP/PBP ON/OFF.	-
21	Cont.	Adjust difference between dark and light.	-
22	Focus	Adjust focus to improve image clarity as desired.	14
23	Zoom	Adjust zoom to achieve a desired image size.	14
24	Pattern	Display a test pattern.	-



Caution:

Use of controls, adjustments or performance of procedures other than those specified herein may result in hazardous laser light exposure.

Remote Control Operating Range

The remote control uses infrared transmission to control the projector. It is not necessary to point the remote directly at the projector. Provided you are not holding the remote perpendicular to the sides or the rear of the projector, the remote will function well within a radius of about 7 meters (23 feet) and 15 degrees above or below the projector level. If the projector does not respond to the remote control, move a little closer.

Projector and Remote Control Buttons

The projector can be operated using the remote control or the buttons on the rear of the projector. All operations can be carried out with the remote control; however, the buttons on the projector are limited in use.

Remote Control Code

The ten different remote control modes (Code 0- Code 9) are assigned to this projector. Switching the remote control codes prevents interference from other remote controls when several projectors or video equipment next to each other are being operated at the same time. Change the remote control code for the projector first before changing that for the remote control. See "Communications menu" on page 42.

To change the code for the Remote Control:

Press and hold the **Mode** button and a number button (0-9) on the remote control for more than three seconds to switch among the codes.

Default setting: 0

To change the Projector Address for the projector:

Select a Projector Address in the Setup Menu. (SETUP → Communications → Projector Address)

Inserting the Remote Control Batteries

1. Remove the battery compartment cover as shown in the illustration.

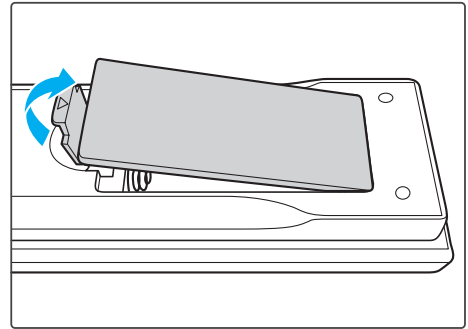

2. Insert the batteries with correct polarity (+/-) as shown inside the battery compartment.

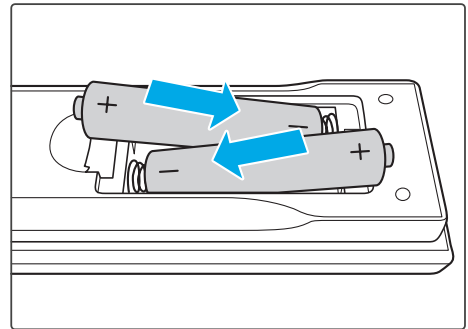

3. Replace the cover.

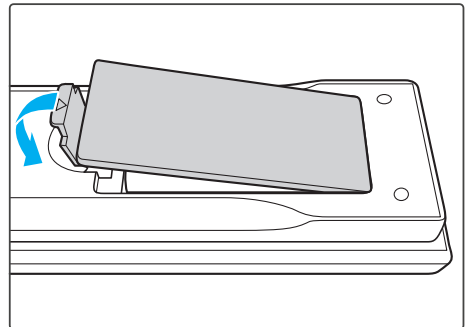

Caution:



- Only use AAA batteries (Alkaline batteries are recommended).
- Dispose of used batteries according to local ordinance regulations.
- Remove the batteries when not using the projector for prolonged periods.

Installing the Projection Lens

Before setting up the projector, install the projection lens on the projector.

Important:

- Before installation, check where the projector is used and prepare a suitable lens.
- For details, contact the sales dealer where you purchased the projector.

1. Press “” on the built-in keypad or press “” on the remote control twice to turn off the projector.
2. Rotate the lens cap counter-clockwise. Then remove the lens cap.

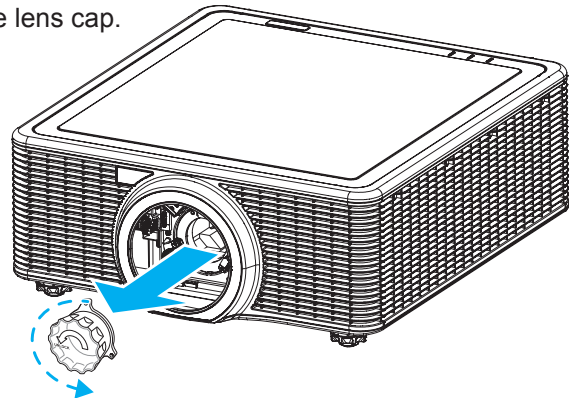

3. Remove both lens caps (front and back) on the lens.

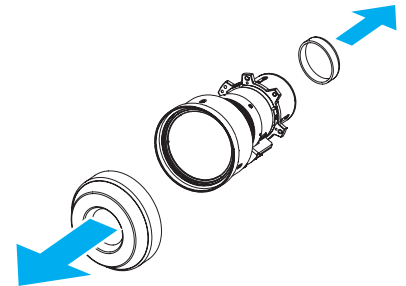

4. With the label “TOP” on the lens assembly facing up, install the assembly into the lens mount.

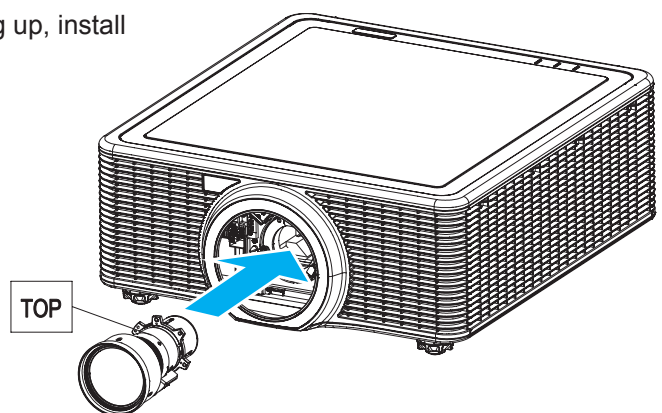

5. Rotate the lens clockwise to lock the lens in place.

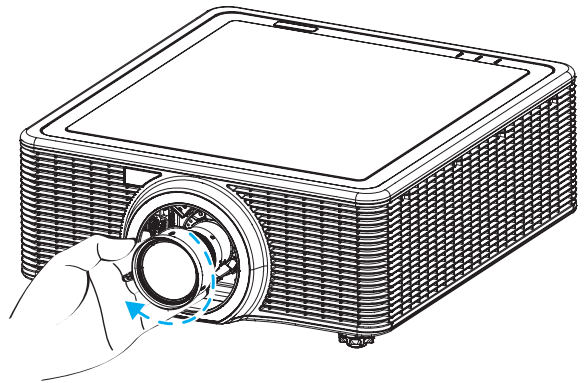

6. Firmly install the lens cover onto the lens.

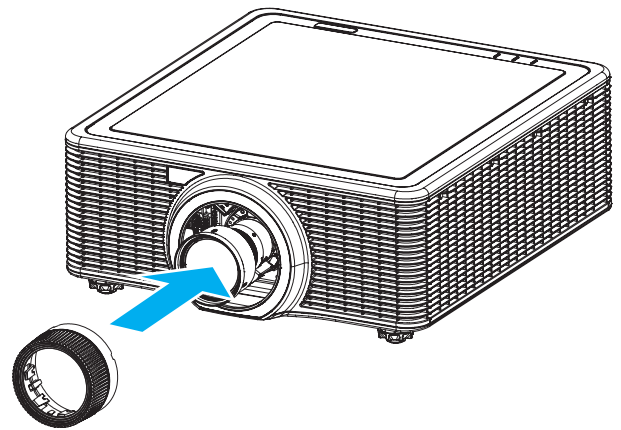

Starting and Shutting down the Projector



Turn the Projector On

1. Connect the power cord to the projector. Then connect the other end to a wall outlet. The Power button on the built in keypad is illuminated.

Important:

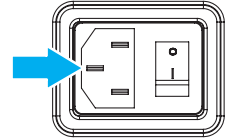
Make sure that the Power switch is in the ON position.









2. Turn on the connected devices.
3. Turn on the projector by pressing “” on the remote control or press “” on the built-in keypad. The Status LED is Orange with a long blink. The projector splash screen displays and connected devices are detected.



4. If more than one input device is connected, press the **Source** key on the remote control to select an input source (HDMI1, HDMI2, DVI-D, VGA, HDBaseT, or 3G-SDI).
5. The projector detects the source you selected and displays the image.

Turn the Projector Off

1. Press “” on the built-in keypad or press “” on the remote control to turn off the projector. A warning message will appear on the displayed image.
2. Press “” on the built-in keypad or press “” on the remote control again to confirm your selection. If you do not press “” or “” again, the warning message will disappear after 10 seconds.

Caution:

Do not unplug the power cord until all of fans are stop—indicating the projector has cooled down.

Adjusting the Projector Level

Take note of the following when setting up the projector:

- The projector table or stand should be level and sturdy.
- Position the projector so that it is perpendicular to the screen.
- Ensure the cables are in a safe location. You could trip over them.

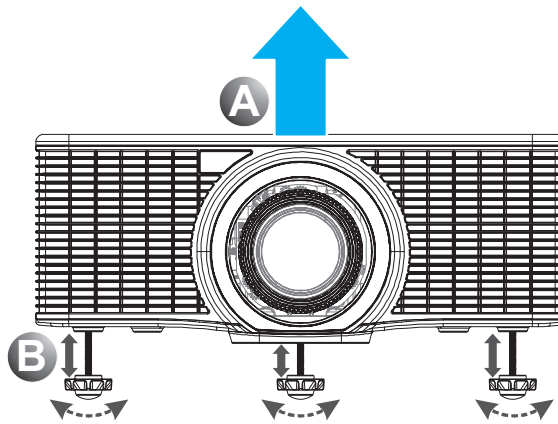

1. To raise the level of the projector, lift the projector **A**.
2. Locate the adjustable foot you wish to modify on the underside of the projector.
3. Rotate the adjustable foot clockwise to raise the projector or counter-clockwise to lower it. Repeat with the remaining feet as necessary **B**.

Adjusting the Zoom, Focus, and Keystone

1. Use the **Zoom** button to resize the projected image and screen size **B**.

2. Use the **Focus** button to sharpen the projected image **A**.

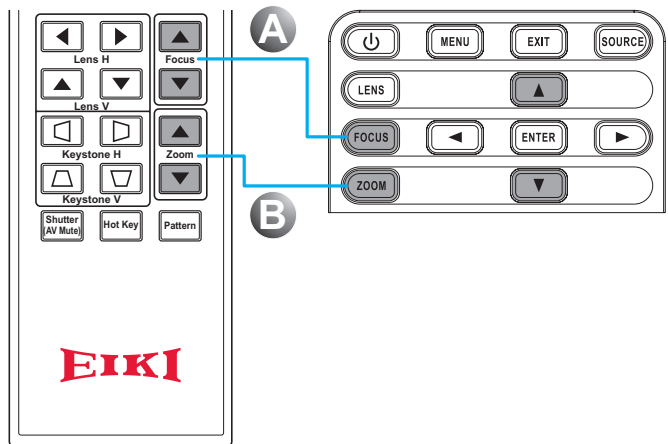

3. Use the **Keystone H** buttons (on the remote control) to adjust the keystone horizontally and make a squarer image. Use the **Keystone V** buttons (on the remote control) to adjust keystone vertically and make a squarer image.

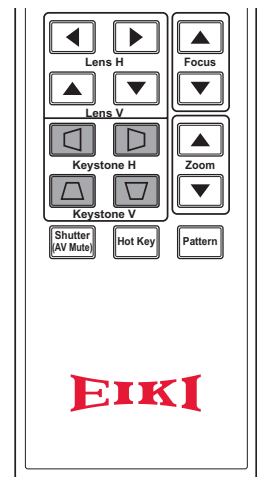

Using the Lens Shift Adjustment

The projection lens can be moved up, down, right, and left with the motor-driven lens shift function. This function makes the positioning of images easy on the screen. Lens shift is generally expressed as a percentage of the image height or width, see below illustration.

Vertical / Horizontal Lens Shift

Vertical Image Offset: 0% Offset (WUXGA)

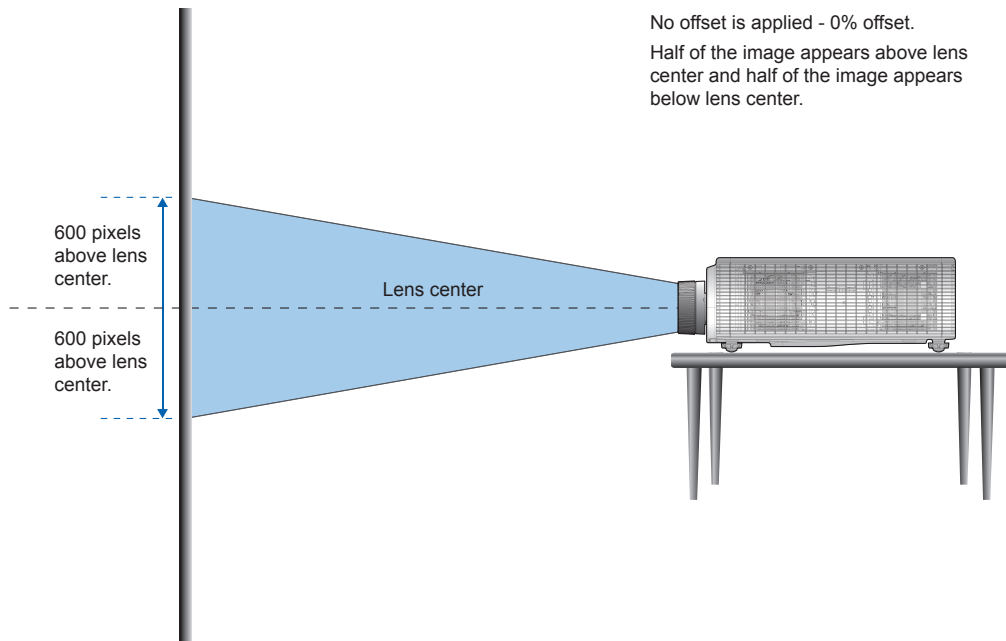

Vertical Image Offset: 50% Offset (WUXGA)

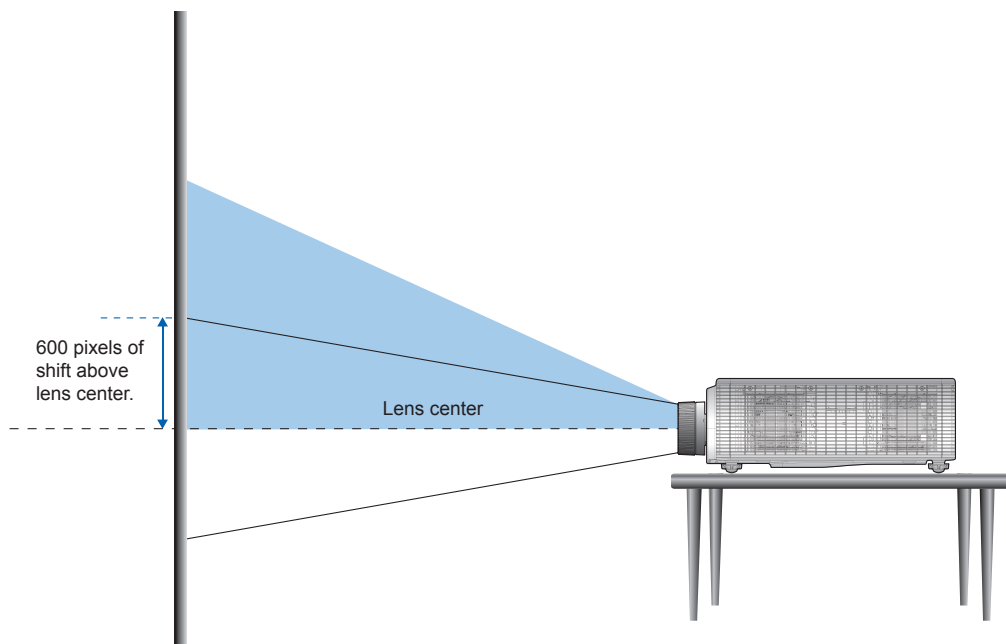

Vertical Image Offset: -50% Offset (WUXGA)

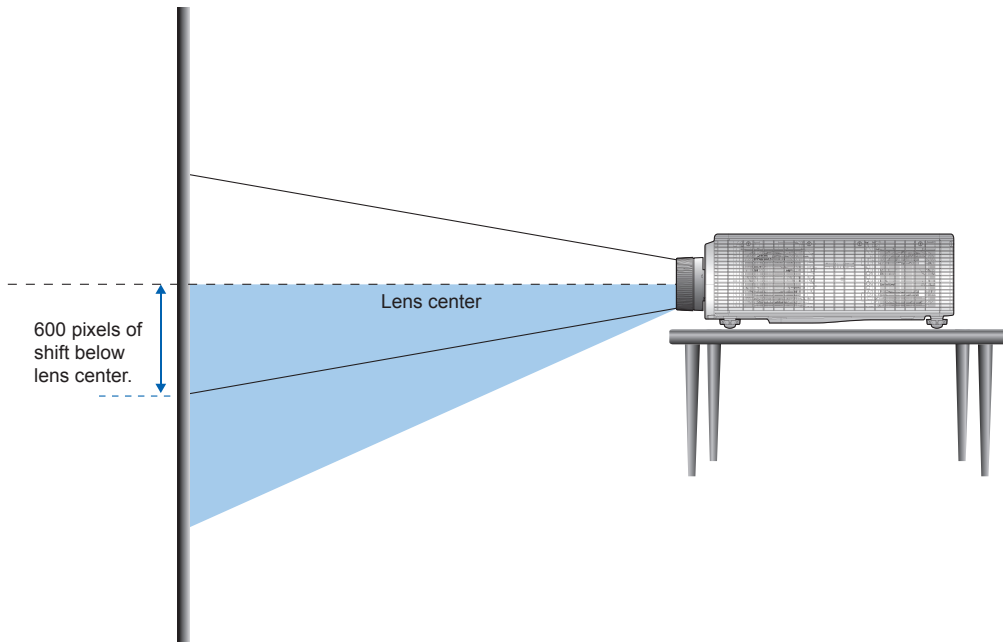

Horizontal Image Offset: +/-15% Offset (WUXGA)

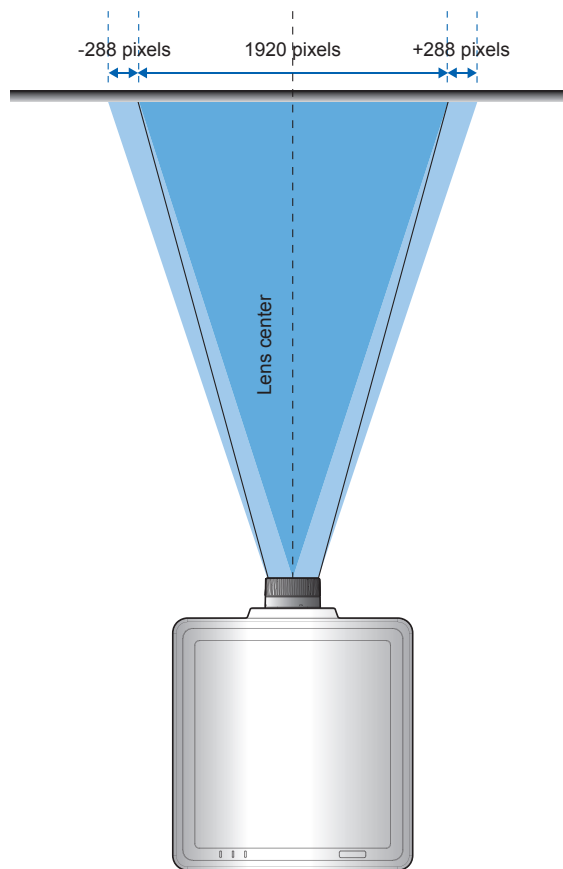

Optional Lenses and Projection Size

Projection Lens

The complete projection lens series as below table.

ITEM	LENS TYPE					
Projection Lens	A16	A15	A01	A06	A03	A13
Focal Length (f)	N/A	11.11-14.06	14.03-17.96	18.2-22.6	22.56-42.87	42.60-80.90
F number	2.4	2.30-2.53	2.30-2.57	2.00-2.30	2.30-3.39	2.30-2.74
Focus spec (MTF)	67 lp/mm	67 lp/mm	67 lp/mm	67 lp/mm	67 lp/mm	67 lp/mm
Zoom Range (Ratio)	N/A	1.26X	1.28X	1.25X	1.9X	1.9X
Zoom & Focus Adjustment	Motorized					
Throw Ratio (WUXGA)	0.361	0.75-0.95	0.95-1.22	1.22-1.52	1.52-2.92	2.90-5.50
Throw Distance (WUXGA)	0.96~3.01m	0.81~6.13m	1.02~7.88m	1.31~9.82m	1.64~18.87m	3.12~35.54m
Projection Image Size	50~300"					
Motorized Lens Shift (Lens shift range based on screen width and height)	Horizontal: ±15%					
	Vertical: ±50%					
	Projection Lens: A01, A03, A13					
	PLATFORM	H	V	△H	△V	
	0.67" WUXGA	15%	50%	15%	50%	
	Projection Lens: A06					
	PLATFORM	H	V	△H	△V	
	0.67" WUXGA	15%	50%	10%	40%	
	Projection Lens: A15					
	PLATFORM	H	V	△H	△V	
0.67" WUXGA	15%	50%	1%	25%		

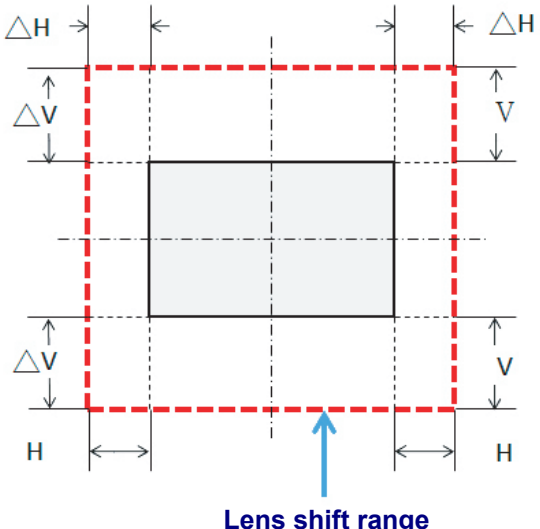
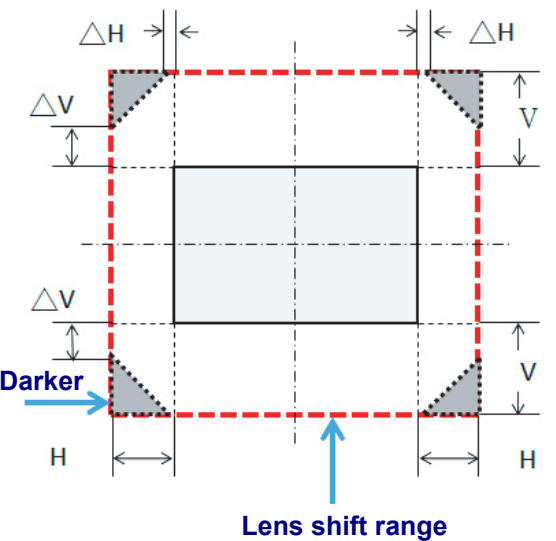
<p>Motorized Lens Shift</p>		<p>A01/A03/A13 lens shift range:</p>  <p>A06/A15 lens shift range:</p>  <ul style="list-style-type: none"> • Lens shift accuracy is 0.5 pixels per step. • When the lens is shifted beyond the described range of operation, the screen edges may become darker or the images may become out of focus.
------------------------------------	--	---

Other Optional Parts:

PART NUMBER	ITEM
AH-B34020	WiFi Dongle
AH-B34030	Wired Remote Cable

Projection Size v.s Throw Distance

PLATFORM			WUXGA (16:10)										
DMD			0.67"										
PROJECTION LENS			A16	A01		A06		A03		A13		A15	
			ULTRA SHORT THROW	WIDE ZOOM		STANDARD		LONG ZOOM		ULTRA-LONG ZOOM		SHORT THROW	
THROW RATIO			0.361 (120")	0.95-1.22		1.22-1.52		1.52-2.92		2.90-5.50		0.75-0.95	
ZOOM RATIO			N/A	1.28X		1.25X		1.9X		1.9X		1.26X	
PROJECTION DISTANCE (M) (MIN/MAX)			0.96-3.01M	1.01-7.98M		1.29-9.93M		1.61-19.00M		3.18-34.77M		0.79-6.21M	
PROJECTION SCREEN SIZE			PROJECTION DISTANCE (M)										
THROW RATIO SPEC.			0.361 (120")	0.95	1.22	1.22	1.52	1.52	2.92	2.9	5.5	0.75	0.95
DIAGONAL (INCH)	HEIGHT (M)	WIDTH (M)	(M)	MIN (M)	MAX (M)	MIN (M)	MAX (M)	MIN (M)	MAX (M)	MIN (M)	MAX (M)	MIN (M)	MAX (M)
50	0.67	1.08	NA	1.01	1.31	1.29	1.62	1.61	3.12	3.18	5.89	0.79	1.01
60	0.81	1.29	NA	1.22	1.57	1.56	1.95	1.94	3.76	3.78	7.05	0.96	1.22
70	0.94	1.51	NA	1.43	1.84	1.82	2.29	2.27	4.39	4.39	8.20	1.12	1.43
80	1.08	1.72	NA	1.63	2.11	2.09	2.62	2.60	5.03	5.00	9.36	1.28	1.64
90	1.21	1.94	NA	1.84	2.38	2.35	2.95	2.94	5.66	5.61	10.51	1.45	1.85
100	1.35	2.15	NA	2.05	2.64	2.62	3.28	3.27	6.30	6.21	11.67	1.61	2.05
110	1.48	2.37	NA	2.26	2.91	2.89	3.62	3.60	6.93	6.82	12.82	1.78	2.26
120	1.62	2.58	0.96	2.47	3.18	3.15	3.95	3.94	7.57	7.43	13.98	1.94	2.47
130	1.75	2.80	1.04	2.67	3.44	3.42	4.28	4.27	8.20	8.04	15.13	2.10	2.68
140	1.88	3.02	1.11	2.88	3.71	3.69	4.61	4.60	8.84	8.65	16.29	2.27	2.89
150	2.02	3.23	1.18	3.09	3.98	3.95	4.95	4.94	9.47	9.25	17.44	2.43	3.09
160	2.15	3.45	1.26	3.30	4.24	4.22	5.28	5.27	10.11	9.86	18.60	2.60	3.30
170	2.29	3.66	1.33	3.51	4.51	4.48	5.61	5.60	10.74	10.47	19.75	2.76	3.51
180	2.42	3.88	1.40	3.72	4.78	4.75	5.94	5.93	11.38	11.08	20.91	2.92	3.72
190	2.56	4.09	1.48	3.92	5.05	5.02	6.27	6.27	12.01	11.69	22.06	3.09	3.93
200	2.69	4.31	1.55	4.13	5.31	5.28	6.61	6.60	12.65	12.29	23.22	3.25	4.13
250	3.37	5.38	1.91	5.17	6.65	6.61	8.27	8.27	15.82	15.33	28.99	4.07	5.17
300	4.04	6.46	2.28	6.21	7.98	7.95	9.93	9.93	19.00	18.37	34.77	4.89	6.21
350	4.71	7.54	2.65	NA									

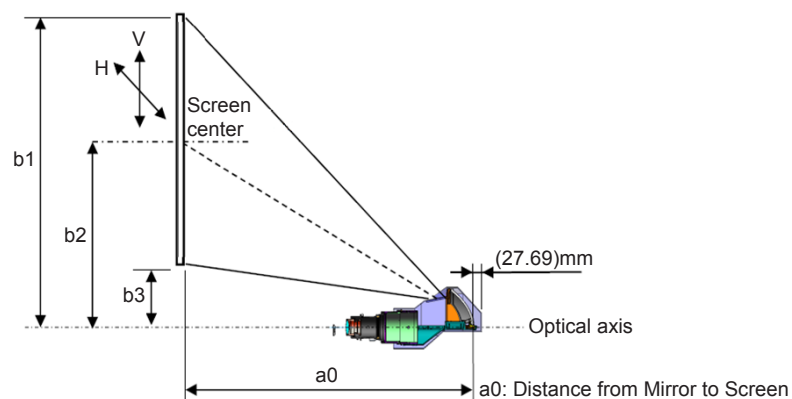

ON-SCREEN DISPLAY (OSD) MENU SETTINGS

OSD Menu Controls

The projector has an OSD that lets you make image adjustments and change various settings.

Navigating the OSD

You can use the remote control cursor buttons or the projector keypad to navigate and make changes to the OSD.

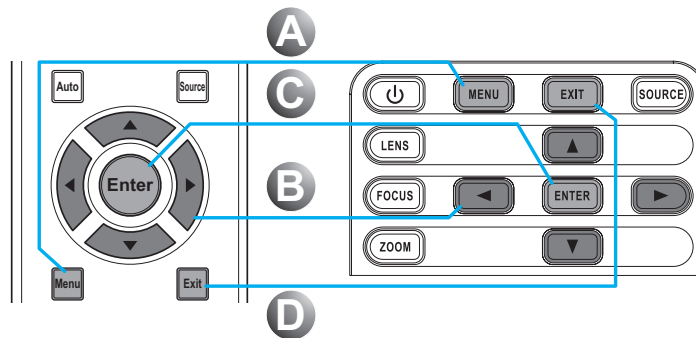

1. To enter the OSD, press the **Menu** button **A**.
2. Use the arrow keys (**▲▼◀▶**) to navigate within the menu and adjust a setting up or down **B**.
3. Press the **Enter** button to enter the submenu or confirm the selection/setting **C**.
4. Press the **Exit** button to return to the previous menu or exit menu if at top level **D**.

PICTURE		PICTURE	
			▲
	Display Mode		Bright
	Save to User		▶
OUTPUT	Wall Color		Off
	Dynamic Range		▶
SETUP	Brightness		50
	Contrast		50
	Sharpness		8
OPTION	Color		50
			▼

Caution:

Depending on the video source, not all items in the OSD are available. Items that are not available cannot be accessed and are grayed out.

Setting the OSD Language

Set the OSD language to your preference before continuing.

1. Press the **Menu** button.

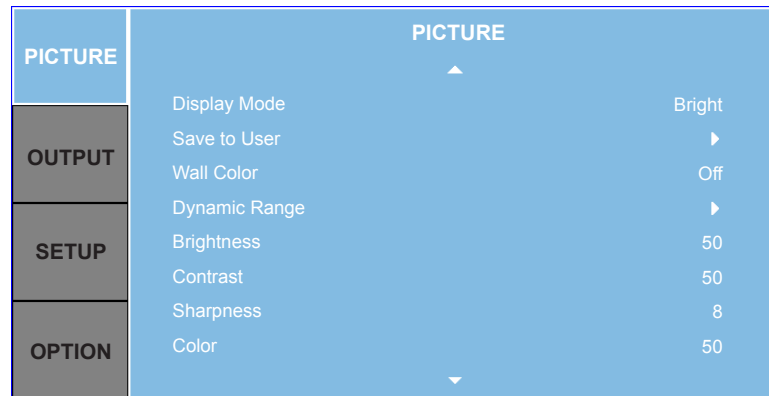

2. Use the arrow keys (▲▼) to select **SETUP** and press the **Enter** button to enter the **SETUP** menu.

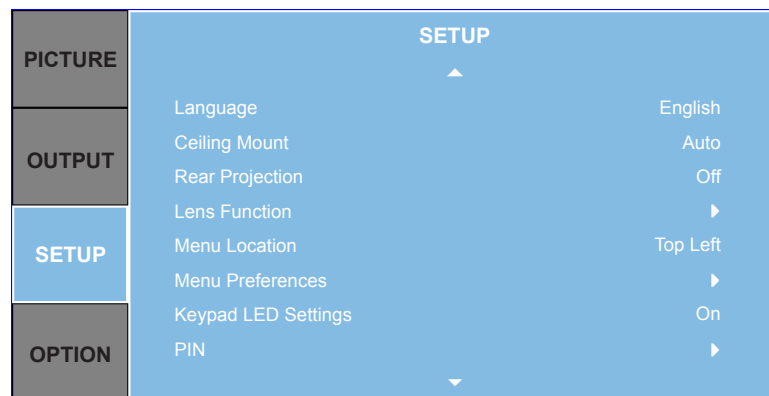

3. Use the arrow keys (▲▼) to select **Language** and press the **Enter** button to enter its submenu.

4. Use the arrow keys (▲▼) to select the desired language and press the **Enter** button to confirm.

5. Press the **Exit** button several times to exit the menu.



OSD Menu Overview

Use the following illustration to quickly find a setting or determine the range for a setting.

MAIN MENU	SUB MENU / SETTINGS			DEFAULT
PICTURE	Display Mode	Presentation		Bright
		Bright		
		Movie		
		HDR		
		sRGB		
		DICOM SIM.		
		Blending		
		2D High Speed		
		User		
		3D		
	Save to User			
	Wall Color	Off		Off
		Blackboard		
		Light Yellow		
		Light Green		
		Light Blue		
		Pink		
		Gray		
	Dynamic Range	HDR	Off	Auto
			Auto	
		HDR Picture Mode	Bright	Standard
			Standard	
			Film	
		Detail		
	Brightness	0 ~ 100		50
	Contrast	0 ~ 100		50
	Sharpness	0 ~ 15		8
	Color	0 ~ 100		50
	Tint	0 ~ 100		50
	Phase	0 ~ 31		0
	Horz Position	0 ~ 100		50
	Vert Position	0 ~ 100		50
Auto Image	Normal		Wide	
	Wide			
3D Display	3D Mode	Off	On	
		On		
	3D Format	Auto	Auto	
		Frame Packing		
		Side by Side		
		Top and Bottom		
	Frame Sequential			

MAIN MENU	SUB MENU / SETTINGS			DEFAULT
PICTURE	3D Display	3D Invert	Off	Off
			On	
		DLP Link	Off	Off
			On	
		3D-2D	3D	3D
			L	
			R	
		3D Sync Out	To Emitter	To Emitter
			To Next Projector	
		L/R Reference	1st Frame	1st Frame
	Field GPIO			
	Frame Delay	1~500	By set	
	HSG Adjustment	HSG Enable	Off	Off
			On	
		Auto Test Pattern	Off	On
			On	
		Red H.	0 ~ 254	127
		Red S.	0 ~ 254	127
		Red G.	0 ~ 254	127
		Green H.	0 ~ 254	127
		Green S.	0 ~ 254	127
		Green G.	0 ~ 254	127
		Blue H.	0 ~ 254	127
		Blue S.	0 ~ 254	127
		Blue G.	0 ~ 254	127
		Cyan H.	0 ~ 254	127
		Cyan S.	0 ~ 254	127
		Cyan G.	0 ~ 254	127
		Magenta H.	0 ~ 254	127
		Magenta S.	0 ~ 254	127
		Magenta G.	0 ~ 254	127
		Yellow H.	0 ~ 254	127
		Yellow S.	0 ~ 254	127
		Yellow G.	0 ~ 254	127
White R Gain		0 ~ 254	127	
White G Gain		0 ~ 254	127	
White B Gain		0 ~ 254	127	
Reset to Default				
Advanced		White Peaking	0 - 10	By source set
	Gamma	Film	By source set	
		Video		
		Graphics		
		Gamma2.2		
		3D		
		Blackboard		
		DICOM		
Vivid				

MAIN MENU	SUB MENU / SETTINGS			DEFAULT	
PICTURE	Advanced	Color Temperature	Warm		By source set
			Standard		
			Cool		
		Color Space	Auto		Auto
			RGB		
			RGB Video		
			REC709		
			REC601		
		Color Settings	Red Gain	0 ~ 100	50
			Green Gain	0 ~ 100	50
			Blue Gain	0 ~ 100	50
			Red Offset	0 ~ 100	50
			Green Offset	0 ~ 100	50
			Blue Offset	0 ~ 100	50
			Reset RGB Gain/ Offset		
		Color Enhancement	Off		CE1
			CE 1		
			CE 2		
		Color Wheel Speed	2X		3X
3X					
Extreme Black	Off		Off		
	On				
DynamicBlack™	Off		Off		
	On				
OUTPUT	Aspect Ratio	Auto		Auto	
		4:3			
		16:9			
		16:10			
		LBX			
		Native			
	Edge Mask	0~10		0	
	H Digital Zoom	50 ~ 400		100	
	V Digital Zoom	50 ~ 400		100	
	H Digital Shift	0 ~ 100		50	
	V Digital Shift	0 ~ 100		50	
	Image Warping	PC Mode	Off	Off	
			On		
		H Keystone	0 ~ 200	100	
V Keystone		0 ~ 200	100		
V Pincushion		0 ~ 100	50		

MAIN MENU	SUB MENU / SETTINGS		DEFAULT		
OUTPUT	Image Warping	4-Corner	Top Left Horz Adjust	0 ~ 240	0
			Top Left Vert Adjust	0 ~ 160	0
			Top Right Horz Adjust	0 ~ 240	0
			Top Right Vert Adjust	0 ~ 160	0
			Bottom Left Horz Adjust	0 ~ 240	0
			Bottom Left Vert Adjust	0 ~ 160	0
			Bottom Right Horz Adjust	0 ~ 240	0
			Bottom Right Vert Adjust	0 ~ 160	0
		Reset to Default			
	PIP/PBP	PIP/PBP Enable	Off		Off
			On		
		Main Source	HDMI1		By set
			HDMI2		
			DVI-D		
			VGA		
			HDBaseT		
			3G-SDI		
		Sub Source	HDMI1		By set
			HDMI2		
			DVI-D		
			VGA		
			HDBaseT		
			3G-SDI		
		Swap			
		Size	Small		Large
			Medium		
			Large		
		Layout	PBP, Main Left		PBP, Main Left
PBP, Main Top					
PBP, Main Right					
PBP, Main Bottom					
PIP-Bottom Right					
PIP-Bottom Left					
PIP-Top Left					
PIP-Top Right					

MAIN MENU	SUB MENU / SETTINGS			DEFAULT	
SETUP	Language	English		English	
		French			
		Spanish			
		German			
		Italian			
		Russian			
		Chinese Simplified			
		Japanese			
		Korean			
		Portuguese			
		Indonesian			
		Dutch			
		Arabic			
	Ceiling Mount	Off		Auto	
		On			
		Auto			
	Rear Projection	Off		Off	
		On			
	Focus			Focus in - motor stop	
				Focus in - motor move 1 step	
				Focus in - motor move 30 steps	
				Focus out - motor stop	
				Focus out - motor move 1 step	
				Focus out - motor move 30 steps	
		Zoom			Zoom in - motor stop
					Zoom in - motor move 1 step
					Zoom in - motor move 30 steps
					Zoom out - motor stop
					Zoom out - motor move 1 step
					Zoom out - motor move 30 steps
		Lens Shift			Left shift up - motor stop
					Left shift up - motor shift 1 pixel
					Left shift up - motor shift 30 pixels
					Left shift down - motor stop
					Left shift down - motor shift 1 pixel
					Left shift down - motor shift 30 pixels
					Left shift right - motor stop
					Left shift right - motor shift 1 pixel
					Left shift right - motor shift 30 pixels
					Left shift left - motor stop
				Left shift left - motor shift 1 pixel	
				Left shift left - motor shift 30 pixels	
Lens Calibration		Yes/No (Dialog box)			
Lens Lock		No		No	
		Yes			
Lens Memory		Apply Position	1~5		
		Save Position	1~5		

MAIN MENU	SUB MENU / SETTINGS			DEFAULT	
SETUP	Menu Location	Top left		Top left	
		Top right			
		Center			
		Bottom left			
		Bottom right			
	Menu Preferences	Menu Transparency	0 ~ 9	0	
		Show Messages	Off	On	
	Keypad LED Settings		Off	On	
		On			
	Pin	PIN Protect	Off	Off	
			On		
		Change PIN			
	12V Trigger	Off	Off		
		On			
	4K Compatible (HDMI1)	Off	On		
		On			
	4K Compatible (HDMI2)	Off	On		
		On			
	Communications	LAN	DHCP	OFF	By set
				ON	
			IP Address		By set
			Subnet Mask		By set
			Default Gateway		By set
			DNS		
			MAC Address		By set
		Apply			
		WLAN	Enable		By set
			Start IP		By set
			End IP		By set
			IP address		
			Subnet Mask		By set
			SSID		By set
Apply					
Control		Crestron	Off	On	
			On		
		PJ Link	Off	On	
			On		
		AMX Device Discovery	Off	On	
			On		
		Telnet	Off	On	
			On		
		HTTP	Off	On	
			On		

MAIN MENU	SUB MENU / SETTINGS			DEFAULT	
SETUP	Communications	Network Reset			By set
		Serial Port Baud Rate	1200		115200
			2400		
			4800		
			9600		
			14400		
			19200		
			38400		
			57600		
			115200		
		Projector Address	0 - 9		0
		IR Control	Front	Off	On
				On	
			Top	Off	On
On					
HDBaseT	Off		Off		
	On				
OPTION	Auto Source	Off	On		
		On			
	High Altitude	Off	Off		
		On			
	Test Pattern	Off	Off		
		Green Grid			
		Magenta Grid			
		White Grid			
		White			
		Black			
		Red			
		Green			
		Blue			
		Yellow			
		Magenta			
		Cyan			
	Background Color	Logo	Logo		
		Blue			
		Black			
		White			
	Hot-Key settings	Aspect Ratio			
		Freeze Screen			
	Power Settings	Standby Power Mode	0.5W mode	Communication mode	
Active mode					
Communication mode					
Direct Power On		Off	Off		
		On			
Signal Power On		Off	Off		
	On				

MAIN MENU	SUB MENU / SETTINGS			DEFAULT	
OPTION	Power Settings	Auto Power Off (min)	0~180 (5 min increments)	20 Mins	
		Sleep Timer (min.)	0 ~ 990 (30 min increments)	0	
	Light Source Settings	Light Source Mode	Constant Power		Constant Power
			Constant Luminance		
			Eco Mode		
		Constant Power Settings	1 ~ 100	100	
		Total Projector Hours			
	Information	Model Name			
		Serial Number			
		Native Resolution			
		FW Version			
		F-MCU Version			
		S-MCU Version			
		M-MCU Version			
		L-MCU Version			
		A-MCU Version			
		LAN Version			
		Formatter Version			
		FPGA0 Version			
		FPGA1 Version			
		HDBaseT Version			
		Main Source			
		- Resolution			
		- Signal Format			
		- Pixel Clock			
		- Horz Refresh			
		- Vert Refresh			
		Sub Source			
		- Resolution			
		- Signal Format			
		- Pixel Clock			
		- Horz Refresh			
		- Vert Refresh			
Display Mode					
Color Space					
Light Source Mode					
Total Projector Hours					
Standby Power Mode					
IP Address					
DHCP					
SSID					
Factory Reset	Yes/No (Dialog box)				
Service					

Picture Menu

Press the **Menu** button to open the OSD menu. Press the arrow keys (▲▼) to select **PICTURE** and press the **Enter** button to enter the **PICTURE** menu. Press the arrow keys (▲▼) to select the menu option and press the **Enter** button to enter its submenu. Press the arrow keys (▲▼◀▶) to select or adjust the desired settings and press the **Enter** button to confirm.

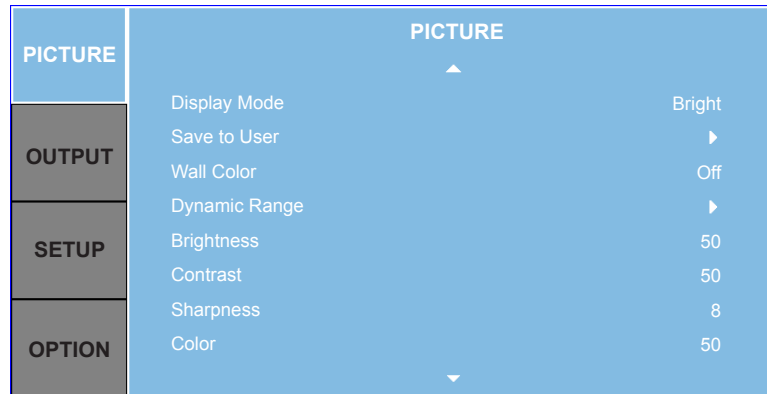

ITEM	DESCRIPTION
Display Mode	Optimize the projector for displaying images under certain conditions, such as Presentation, Bright, Movie, HDR, sRGB, DICOM SIM., Blending, 2D High Speed, User (user-definable preset), and 3D.
Save to User	Save the current picture settings in user profile, including brightness, contrast, color, tint, color space, HSG adjustment and so on.
Wall Color	Select a similar color to the wall color from the preset six colors, such as Blackboard, Light Yellow, Light Green, Light Blue, Pink, and Gray. Select Off to disable the function.
Dynamic Range	Configure the High Dynamic Range (HDR) setting and its effect when displaying video from 4K Blu-ray players and streaming devices.
Brightness	Adjust the intensity of the image.
Contrast	Adjust the degree of difference between the lightest and darkest parts of the picture and change the amount of black and white in the image.
Sharpness	Select the edge clarity of the image.
Color	Adjust a video image from black and white to fully saturated color. The color setting applies to video sources only.
Tint	Adjust the red-green color balance in the image of video images. The tint setting applies to video sources only.
Phase	Analog signals only. Adjust pixel phase when the image still shows shimmer or noise after pixel tracking is optimized. Pixel phase can adjust the phase of the pixel-sampling clock relative to the incoming signal.
Horz Position	Move the image right or left within the area of available pixels.
Vert Position	Move the image up or down within the area of available pixels.
Auto Image	Force the projector to reacquire and lock to the input signal. This is useful when signal quality is marginal.
3D Display	Configure the 3D display settings. See “3D Display Menu” on page 31.
HSG Adjustment	Configure the color management settings. See “HSG Adjustment Menu” on page 32.
Advanced	Configure the advanced image settings. See “Advanced Menu” on page 33.

3D Display Menu

Press the **Menu** button to open the OSD menu. Press the arrow keys (▲▼) to select **PICTURE** and press the **Enter** button to enter the **PICTURE** menu. Press the arrow keys (▲▼) to select **3D Display** and press the **Enter** button to enter the **3D Display** menu. Press the arrow keys (▲▼) to select the menu option and press the **Enter** button to enter its submenu. Press the arrow keys (▲▼◀▶) to select or adjust the desired settings and press the **Enter** button to confirm.

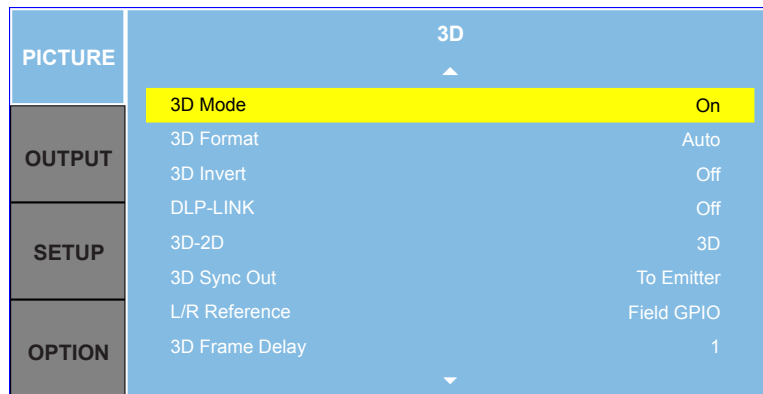

ITEM	DESCRIPTION
3D Mode	Enable to display 3D content.
3D Format	Set 3D format. Supports Auto (automatically detects format), Frame Packing, Side by Side, Top and Bottom, and Frame Sequential.
3D Invert	Invert 3D sync signal for the application of using single projector.
DLP Link	Select 3D Sync source: <ul style="list-style-type: none"> • On: 3D Sync type is DLP link. • Off: 3D Sync source is from the 3D SYNC OUT port.
3D-2D	Set how the 3D content is displayed on the screen: 3D (display 3D signal), left (L) (display the left frame of the 3D content), or right (R) (display the right frame of the 3D content).
3D Sync Out	Transmit a 3D sync signal by the 3D sync output corrector to the emitter (To Emitter) or to the next projector (To Next Projector) for 3D blending purposes.
L/R Reference	Set the source of the left or right reference, such as 1ST Frame (used for single 3D projector) and Field GPIO (make the 3D output signal the same for multiprojectors application).
Frame Delay	Set the frame delay to correct asynchronous displaying image in 3D blending.

HSG Adjustment Menu

Press the **Menu** button to open the OSD menu. Press the arrow keys (▲▼) to select **PICTURE** and press the **Enter** button to enter the **PICTURE** menu. Press the arrow keys (▲▼) to select **HSG Adjustment** and press the **Enter** button to enter the **HSG Adjustment** menu. Press the arrow keys (▲▼) to select the menu option and press the **Enter** button to enter its submenu. Press the arrow keys (▲▼◀▶) to select or adjust the desired settings and press the **Enter** button to confirm.

PICTURE	HSG Adjustment	
	HSG Enable	On
OUTPUT	Auto Test Pattern	On
	Red H.	127
	Red S.	127
SETUP	Red G.	127
	Green H.	127
	Green S.	127
OPTION	Green G.	127

ITEM	DESCRIPTION
HSG Enable	Enable/Disable the HSG adjustment function.
Auto Test Pattern	Enable/Disable solid colored test pattern according to the menu item on which you are positioned.
Red H. / Green H. / Blue H. / Cyan H. / Magenta H. / Yellow H.	Adjust the hue of the red, green, blue, cyan, magenta, or yellow channel of the image.
Red S./ Green S./ Blue S./ Cyan S./ Magenta S./ Yellow S.	Adjust the saturation of the red, green, blue, cyan, magenta, or yellow channel of the image.
Red G. / Green G. / Blue G. / Cyan G. / Magenta G. / Yellow G.	Adjust the gain of the red, green, blue, cyan, magenta, or yellow channel of the image.
White R Gain / White G Gain / White B Gain	Adjust the white balance of the red, green, or blue channel of the image.
Reset to Default	Reset the hue, saturation, gain, and white balance adjustments to the factory defaults.

Advanced Menu

Press the **Menu** button to open the OSD menu. Press the arrow keys (▲▼) to select **PICTURE** and press the **Enter** button to enter the **PICTURE** menu. Press the arrow keys (▲▼) to select **Advanced** and press the **Enter** button to enter the **Advanced** menu. Press the arrow keys (▲▼) to select the menu option and press the **Enter** button to enter its submenu. Press the arrow keys (▲▼◀▶) to select or adjust the desired settings and press the **Enter** button to confirm.

PICTURE	Advanced	
OUTPUT	White Peaking	10
	Gamma	Video
	Color Temperature	Standard
	Color Space	Auto
SETUP	Color Settings	
	Color Enhancement	CE 1
	Color Wheel Speed	2X
OPTION	Extreme Black	Off

ITEM	DESCRIPTION
White Peaking	(Video source only) Increase the brightness of whites that are near 100%.
Gamma	Select the appropriate gamma from Film, Video, Graphics, Gamma2.2, 3D, Blackboard, DICOM, and Vivid.
Color Temperature	Change the intensity of the colors from Warm, Standard, and Cool.
Color Space	Select a color space that has been specifically tuned for the input signal. Use only for analog signals and certain digital sources. Available options: Auto, RGB, RGB Video, REC709, and REC601.
Color Settings	Adjust the gain of the red, green, or blue channel of the image. It will affect the black and white. Adjust the offset of the red, green, or blue channel of the image. It will affect the black and white. Reset RGB Gain/Offset to return the factory default settings for color adjustments.
Color Enhancement	The Color Enhancement control can improve the picture quality of pictures with a high saturation of color.
Color Wheel Speed	Higher speed will reduce the appearance of color artifacts seen by some people. Color Wheel Speed can be set to 2x to provide quieter sound and longer light source life, or 3X to provide better color performance.
Extreme Black	Analyze the current input image and calculate an offset value which is then added to the analog to digital converter black level value. This ensures optimum black level for each analog source.
DynamicBlack™	Enable or disable the dynamic black function. Enable this function raises the contrast ratio dynamically.

Output Menu

Press the **Menu** button to open the OSD menu. Press the arrow keys (▲▼) to select **OUTPUT** and press the **Enter** button to enter the **OUTPUT** menu. Press the arrow keys (▲▼) to select the menu option and press the **Enter** button to enter its submenu. Press the arrow keys (▲▼◀▶) to select or adjust the desired settings and press the **Enter** button to confirm.

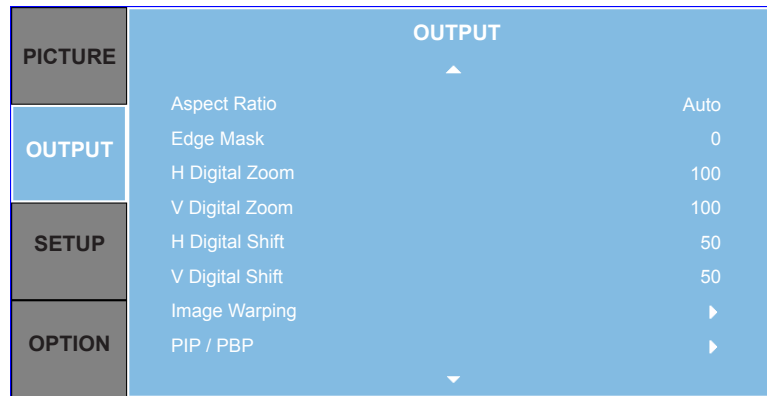

ITEM	DESCRIPTION
Aspect Ratio	Display an image with the detected size, or resize the image by maximizing either the height, width or both, or resize to the maximum size possible while keeping the original aspect ratio. Available options: Auto, 4:3, 16:9, 16:10, LBX, and Native.
Edge Mask	Remove the video encoding noise on the edge of video source.
H Digital Zoom	Change the size of projector's display area horizontally. If the display area has been resized by this setting, it can be moved by changing the H Digital Shift and V Digital Shift settings.
V Digital Zoom	Change the size of projector's display area vertically. If the display area has been resized by this setting, it can be moved by changing the H Digital Shift and V Digital Shift settings.
H Digital Shift	Move the display area horizontally if its size has been changed by the Digital Zoom setting.
V Digital Shift	Move the display area vertically if its size has been changed by the Digital Zoom setting.
Image Warping	Configure the image warping settings. See "Image Warping Menu" on page 35.
PIP/PBP	Configure the PIP/PBP settings. See "PIP/PBP Menu" on page 36.

Note:

- When 16:9 Aspect Ratio is selected, the resolution of the input signal or 1600x1200 will automatically be switched to 1600x900.
- If Auto is selected and input signal is 16:9, screen type will auto become (1920x1200).
- If Native is selected, the screen will automatically become 1:1 mapping centered.

Image Warping Menu

Press the **Menu** button to open the OSD menu. Press the arrow keys (▲▼) to select **OUTPUT** and press the **Enter** button to enter the **OUTPUT** menu. Press the arrow keys (▲▼) to select **Image Warping** and press the **Enter** button to enter the **Image Warping** menu. Press the arrow keys (▲▼) to select the menu option and press the **Enter** button to enter its submenu. Press the arrow keys (▲▼◀▶) to select or adjust the desired settings and press the **Enter** button to confirm.

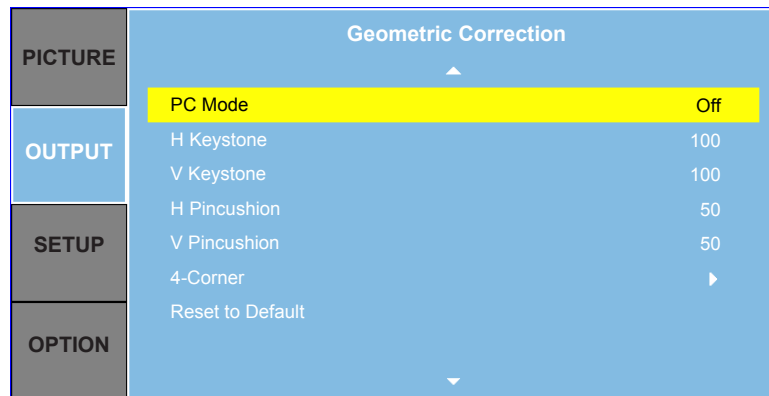

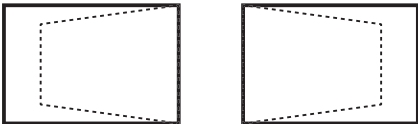
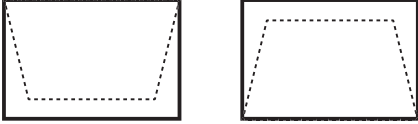
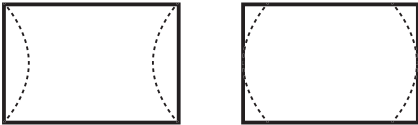
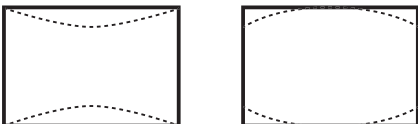
ITEM	DESCRIPTION
PC Mode	Enable PC software to control geometry.
H Keystone	Adjust the keystone horizontally and make a squarer image. Horizontal keystone is used to correct a keystone image shape in which the left and right borders of the image are unequal in length. This is intended for use with horizontally on-axis applications. 
V Keystone	Adjust the keystone vertically and make a squarer image. Vertical keystone is used to correct a keystone image shape in which the top and bottom are slanted to one of the sides. This is intended when for use with vertically on-axis applications. 
H Pincushion	Adjust the pincushion horizontally and make a more square image. 
V Pincushion	Adjust the pincushion vertically and make a more square image. 

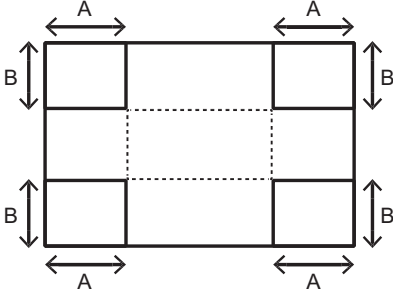
ITEM	DESCRIPTION
4-Corner	<p>Allow the image to be squeezed to fit an area defined by moving each of the four corners' x and y position.</p> 
Reset to Default	Reset the Image Warping setting to the factory defaults.

PIP/PBP Menu

Press the **Menu** button to open the OSD menu. Press the arrow keys (▲▼) to select **OUTPUT** and press the **Enter** button to enter the **OUTPUT** menu. Press the arrow keys (▲▼) to select **PIP/PBP** and press the **Enter** button to enter the **PIP/PBP** menu. Press the arrow keys (▲▼) to select the menu option and press the **Enter** button to enter its submenu. Press the arrow keys (▲▼◀▶) to select or adjust the desired settings and press the **Enter** button to confirm.

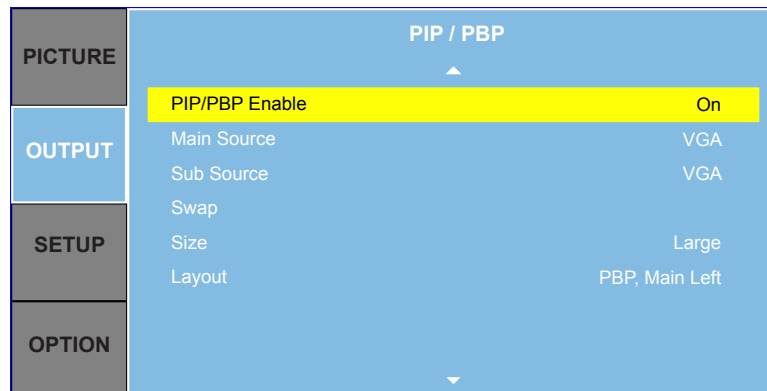

ITEM	DESCRIPTION
PIP/PBP Enable	Toggle between displaying two sources at once (Main and PIP/PBP images) or one source only.
Main Source	From the list of active inputs, select one to be used as the main image.
Sub Source	From the list of active inputs, select one to be used as the PIP/PBP.
Swap	Change the main image to PIP/PBP, and the PIP/PBP to main image. Swapping is available only when PIP/PBP is enabled.
Size	Select the PIP/PBP size. Available options: Small, Medium, or Large.
Layout	Set the location of the PIP/PBP image on the screen.

PIP/PBP layout and size table as described below.

➤ P : indicates primary source region (lighter color).

➤ * : Both source regions are the same size.

PIP/PBP LAYOUT	PIP/PBP SIZE		
	SMALL	MEDIUM	LARGE
PBP, Main Left			
PBP, Main Top			
PBP, Main Right			
PBP, Main Bottom			
PIP-Bottom Right			
PIP-Bottom Left			
PIP-Top Left			
PIP-Top Right			

PIP/PBP MATRIX	VGA	DVI-D	HDMI-1	HDMI-2	HDBaseT	3G-SDI
VGA	—	V	V	V	V	V
DVI-D	V	—	V	V	V	V
HDMI-1	V	V	—	V	V	V
HDMI-2	V	V	V	—	V	V
HDBaseT	V	V	V	V	—	V
3G-SDI	V	V	V	V	V	—

Setup Menu

Press the **Menu** button to open the OSD menu. Press the arrow keys (▲▼) to select **SETUP** and press the **Enter** button to enter the **SETUP** menu. Press the arrow keys (▲▼) to select the menu option and press the **Enter** button to enter its submenu. Press the arrow keys (▲▼◀▶) to select or adjust the desired settings and press the **Enter** button to confirm.

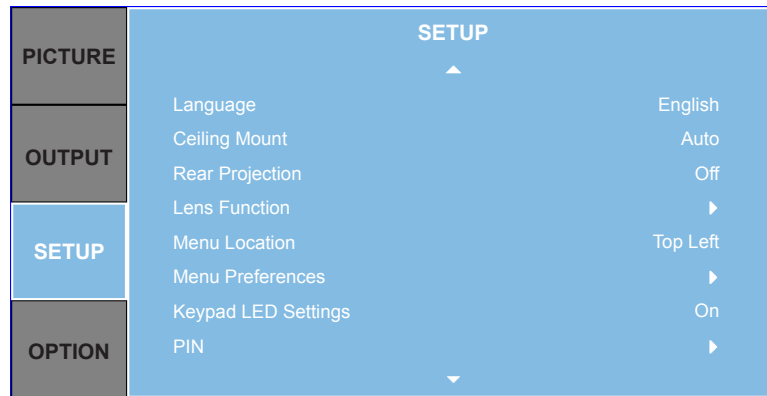

ITEM	DESCRIPTION
Language	This item allows you to select an available language for the OSD display.
Ceiling Mount	Turn the image upside down for ceiling-mounted projection.
Rear Projection	Reverse the image so you can project from behind a translucent screen.
Lens Function	Configure the lens function settings. See “Lens Function Menu” on page 39.
Menu Location	Set the menu location on the display screen. Available options: Top Left, Top Right, Center, Bottom Left, and Bottom Right.
Menu Preferences	Configure the menu preferences settings. See “Menu Preferences Menu” on page 40.
Keypad LED Settings	Turn the backlight of the keypad on/off.
PIN	Configure the PIN settings. See “PIN Menu” on page 40.
12V Trigger	Set the setting to On to turn on the 12V trigger when the lamp is lighted. Set to Off to disable the 12 trigger turning in any state.
4K Compatible (HDMI1)(*) / 4K Compatible (HDMI2)(*)	Set to On to enable EDID of HDMI 2.0 for the HDMI1 or HDMI2 port.
Communications	Configure the communications settings. See “Communications Menu” on page 41.

Note:

- (*)The common HDMI versions are HDMI 1.4 and 2.0. With HDMI 1.4, the rate of 4K is limited to 30 frames per second, whereas HDMI 2.0 plays 4K video without compromise, at 50 and 60 frames per second. This projector supports both HDMI 1.4 and 2.0. In order to play the HDMI content properly, set up the projector EDID for the input devices with different HDMI specifications.

Lens Function Menu

Press the **Menu** button to open the OSD menu. Press the arrow keys (▲▼) to select **SETUP** and press the **Enter** button to enter the **SETUP** menu. Press the arrow keys (▲▼) to select **Lens Function** and press the **Enter** button to enter the **Lens Function** menu. Press the arrow keys (▲▼) to select the menu option and press the **Enter** button to enter its submenu. Press the arrow keys (▲▼◀▶) to select or adjust the desired settings and press the **Enter** button to confirm.

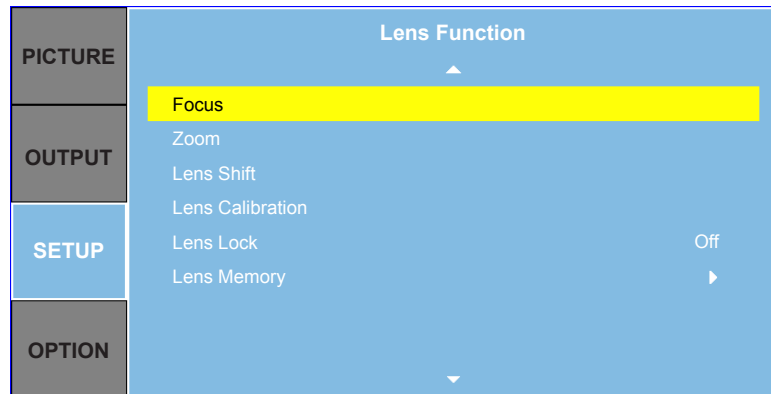

ITEM	DESCRIPTION
Focus	Adjust focus function on the projected image.
Zoom	Adjust zoom function on the projected image.
Lens Shift	Shift the projected image.
Lens Calibration	Perform calibration and return lens to the center position.
Lens Lock	Select this function to prevent all lens motors from moving. <ul style="list-style-type: none"> • Yes: Lens shift will be locked. • No: Lens shift can be used by user.
Lens Memory	Save the current lens position after doing lens shift. Apply lens position to the chosen set of lens memory. The lens memory can be set and saved up to maximum five.

Menu Preferences Menu

Press the **Menu** button to open the OSD menu. Press the arrow keys (▲▼) to select **SETUP** and press the **Enter** button to enter the **SETUP** menu. Press the arrow keys (▲▼) to select **Menu Preferences** and press the **Enter** button to enter the **Menu Preferences** menu. Press the arrow keys (▲▼) to select the menu option and press the **Enter** button to enter its submenu. Press the arrow keys (▲▼◀▶) to select or adjust the desired settings and press the **Enter** button to confirm.

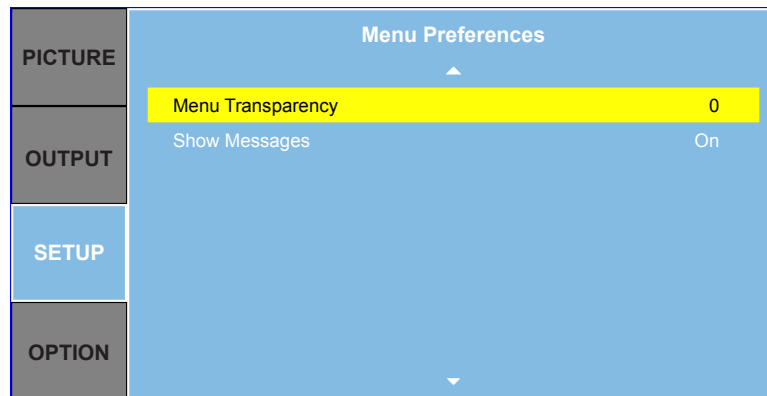

ITEM	DESCRIPTION
Menu Transparency	Change OSD menu background to be transparent.
Show Messages	Display status messages on the screen.

PIN Menu

Press the **Menu** button to open the OSD menu. Press the arrow keys (▲▼) to select **SETUP** and press the **Enter** button to enter the **SETUP** menu. Press the arrow keys (▲▼) to select **PIN** and press the **Enter** button to enter the **PIN** menu. Press the arrow keys (▲▼) to select the menu option and press the **Enter** button to enter its submenu. Press the arrow keys (▲▼◀▶) to select or adjust the desired settings and press the **Enter** button to confirm.

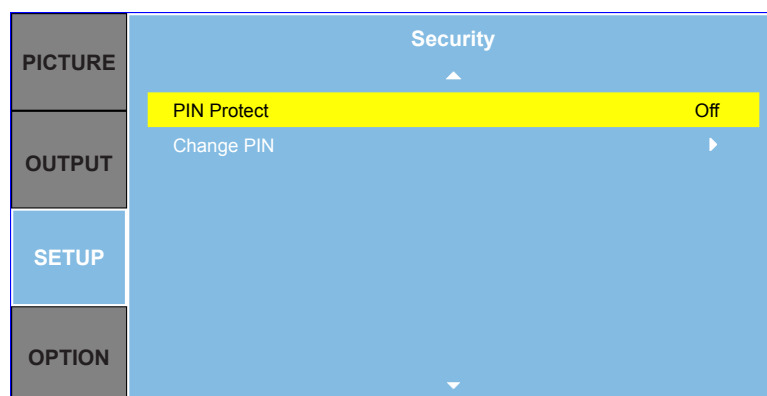

ITEM	DESCRIPTION
PIN Protect	The PIN (personal identification number) feature allows you to password protect your projector. Once you enable the PIN feature, you must enter the PIN before you can project an image. (PIN Default: 12345)
Change PIN	Change the PIN.

Communications Menu

Press the **Menu** button to open the OSD menu. Press the arrow keys (▲▼) to select **SETUP** and press the **Enter** button to enter the **SETUP** menu. Press the arrow keys (▲▼) to select **Communications** and press the **Enter** button to enter the **Communications** menu. Press the arrow keys (▲▼) to select the menu option and press the **Enter** button to enter its submenu. Press the arrow keys (▲▼◀▶) to select or adjust the desired settings and press the **Enter** button to confirm.

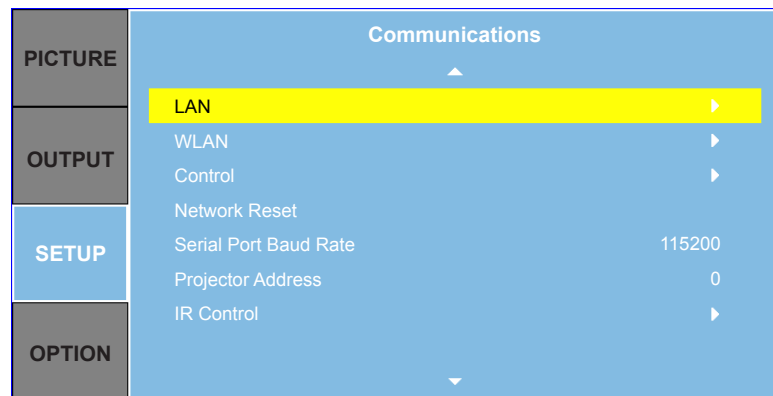

ITEM	DESCRIPTION
LAN	Configure the local area network (LAN) settings. <ul style="list-style-type: none"> • DHCP: Turn the DHCP ON/OFF. • IP Address: Assign Network IP Address. • Subnet Mask: Assign Network Subnet Mask. • Default Gateway: Assign Network Default Gateway. • DNS: Assign DNS. • MAC Address: Display the network MAC Address value. • Apply: Apply Network settings.
WLAN	Configure the wireless local area network (WLAN) settings. <ul style="list-style-type: none"> • Enable: Enable/Disable WLAN. • Start IP: Start of IP Address. • End IP: End of IP Address. • IP Address: Assign Network IP Address. • Subnet Mask: Assign Network Subnet Mask. • SSID: Assign Network Service Set Identifier. • Apply: Apply Network settings.
Control	Configure network control settings. <ul style="list-style-type: none"> • Crestron: Use this function to select the network function (port: 41794). • PJ Link: Use this function to select the network function (port: 4352). • AMX Device Discovery: Use this function to select the network function (port: 9131). • Telnet: Use this function to select the network function (port: 3023). • HTTP: Use this function to select the network function (port: 80).
Network Reset	Reset network setting to the factory defaults.
Serial Port Baud Rate	Select the serial port its baud rate. Available options: 1200, 2400, 4800, 9600, 14400, 19200, 38400, 57600, and 115200.

ITEM	DESCRIPTION	
Projector Address	Set the projector address. The projector will respond to IR remotes set either at the same address as the projector or to IR remotes set to address 0.	
IR Control	Front:	ON: Enable the Front IR Sensor OFF: Disable the Front IR Sensor
	Top	ON: Enable the Top IR Sensor OFF: Disable the Top IR Sensor
	HDBaseT(*)	ON: Enable control signal via HDBaseT device OFF: Disable control signal via HDBaseT device

Note:

- (*)Change the setting ON / OFF depending on the device, if IR remote control of the projector does not work.

Option Menu

Press the **Menu** button to open the OSD menu. Press the arrow keys (▲▼) to select **OPTION** and press the **Enter** button to enter the **OPTION** menu. Press the arrow keys (▲▼) to select the menu option and press the **Enter** button to enter its submenu. Press the arrow keys (▲▼◀▶) to select or adjust the desired settings and press the **Enter** button to confirm.

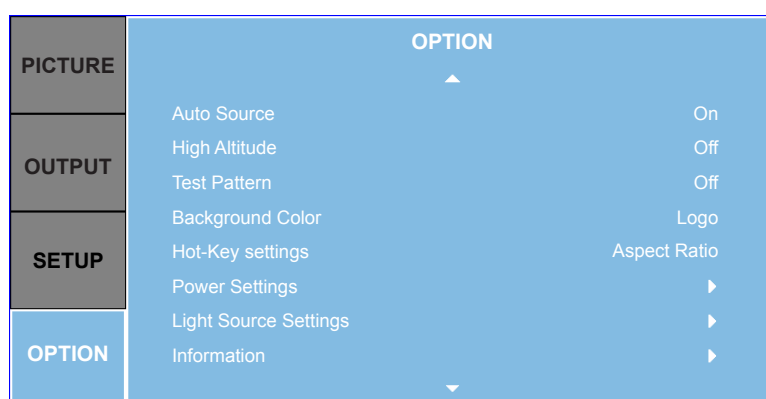

ITEM	DESCRIPTION
Auto Source	Select "On" to allow the projector to search for other signals if the current input signal is lost. When the setting is disabled, the projector will only search current input connection.
High Altitude	Set high altitude mode On/Off. When On, the fan will operate at high speed to ensure sufficient air flow for high altitudes.
Test Pattern	Choose the desired internal test pattern to display. Press the Pattern button to display next test pattern. Available options: Green Grid, Magenta Grid, White Grid, White, Black, Red, Green, Blue, Yellow, Magenta, and Cyan. Select Off to disable the function.
Background Color	Use this feature to display a Logo, Blue, Black or White screen when no signal is available.

ITEM	DESCRIPTION
Hot-Key settings	Assign Aspect Ratio or Freeze Screen as a hot-key on the remote control by highlighting the desired function in the list and pressing the Enter button. Choose a function that does not already have a dedicated button, and assign the hot-key to that function, allowing you to quickly and easily use either of the chosen functions.
Power Settings	Configure the power settings. See "Power Settings Menu" on page 43.
Light Source Settings	Configure the light source settings. See "Light Source Settings Menu" on page 44.
Information	Display various projector related information on the screen.
Factory Reset	Restore all settings to their default value. It will not reset network. WARNING: After resetting, lens calibration is necessary.
Service	For service only.

Power Settings Menu

Press the **Menu** button to open the OSD menu. Press the arrow keys (▲▼) to select **OPTION** and press the **Enter** button to enter the **OPTION** menu. Press the arrow keys (▲▼) to select **Power Settings** and press the **Enter** button to enter the **Power Settings** menu. Press the arrow keys (▲▼) to select the menu option and press the **Enter** button to enter its submenu. Press the arrow keys (▲▼◀▶) to select or adjust the desired settings and press the **Enter** button to confirm.

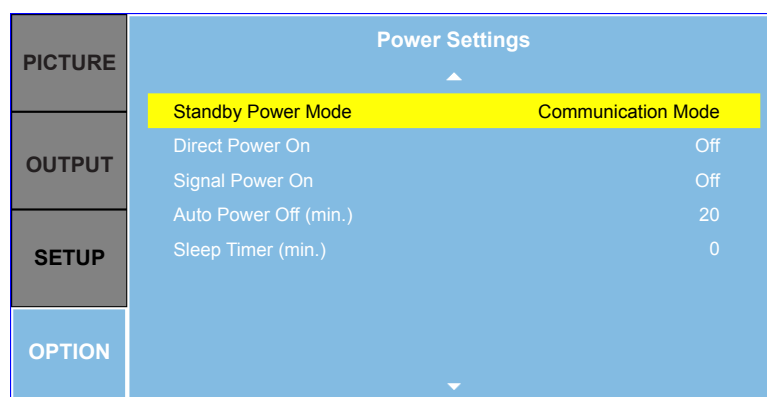

ITEM	DESCRIPTION
Standby Power Mode	Set the standby power mode. <ul style="list-style-type: none"> 0.5W mode: The projector is in standby mode when connected to AC power. (<0.5W) Active mode: Low power consumption (< 2 Watt) which allows the LAN module to enter sleep mode and supports to be woken by Wake on LAN (WoL). When the LAN module is woken by WoL, the projector is ready to receive commands over the network. Communication mode: The projector could be controlled via the LAN terminal during power standby.
Direct Power On	The projector automatically turns on when electrical power is connected.
Signal Power On	Choose On to activate Signal Power On. The projector will automatically turn on after detecting HDMI input source. The available options include On and Off.

ITEM	DESCRIPTION
Auto Power Off (min.)	Automatically turns the projector off after no signals are detected for a preset number of minutes. If an active signal is received before the projector powers down, the image will be displayed.
Sleep Timer (min.)	This item allows the projector to automatically power off after it has been on for a specified amount of time.

Light Source Settings Menu

Press the **Menu** button to open the OSD menu. Press the arrow keys (▲▼) to select **OPTION** and press the **Enter** button to enter the **OPTION** menu. Press the arrow keys (▲▼) to select **Light Source Settings** and press the **Enter** button to enter the **Light Source Settings** menu. Press the arrow keys (▲▼) to select the menu option and press the **Enter** button to enter its submenu. Press the arrow keys (▲▼◀▶) to select or adjust the desired settings and press the **Enter** button to confirm.

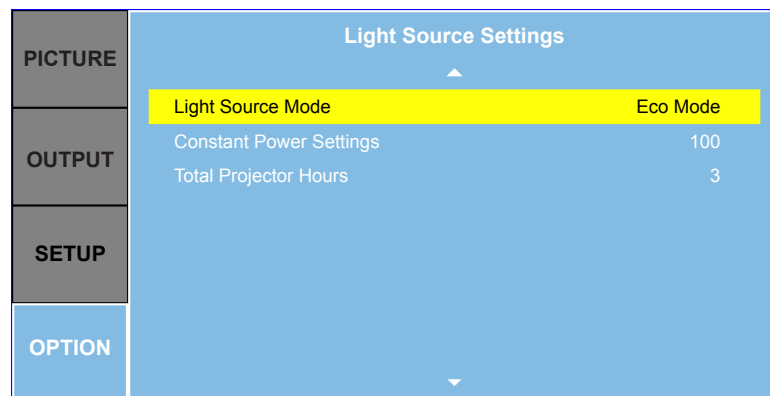

ITEM	DESCRIPTION
Light Source Mode	Select Constant Power, Constant Luminance, or Eco Mode. When in Eco Mode, the projector will adjust to the lowest fan speed and switch the light source power to the minimum setting.
Constant Power Settings	Set the value of the light source power (in Watts).
Total Projector Hours	Display the projection time.

Control Your Projector Using Web Browser

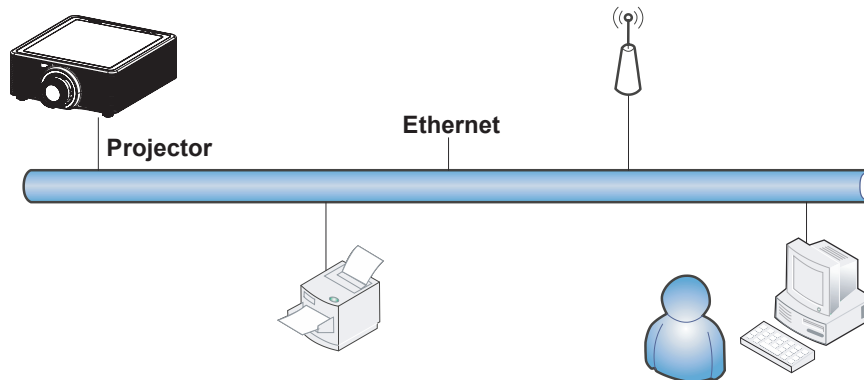

Wired LAN Terminal functionalities

Remote control and monitoring of a projector from a PC (or Laptop) via wired LAN is also possible. Compatibility with Crestron control boxes enables not only collective projector management on a network but also management from a control panel on a PC (or Laptop) browser screen.

- Crestron is a registered trademark of Crestron Electronics, Inc. of the United States.

Supported External Devices

This projector is supported by the specified commands of the Crestron Electronics controller and related software (ex, RoomView®).

<http://www.crestron.com/>

The projector supports AMX and PJ-Link as well.

<http://www.amx.com/>

<http://pjlink.jbmia.or.jp/>

For more detail of information about the diverse types of external devices which can be connected to the Ethernet port and remote/control the projector, as well as the related control commands supporting for each external device, kindly please get contact with the Support-Service team directly.

LAN_RJ45

1. Connect an RJ45 cable to Ethernet port on the projector and the PC (Laptop).

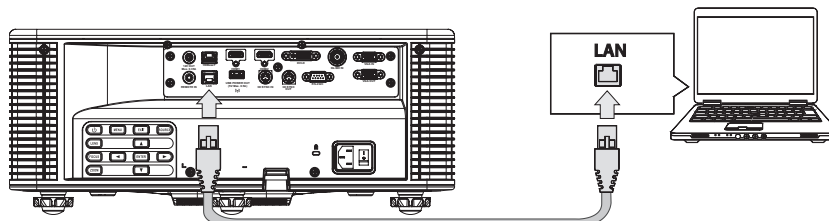

2. On the PC (Laptop), select **Start** → **Control Panel** → **Network and Internet**.

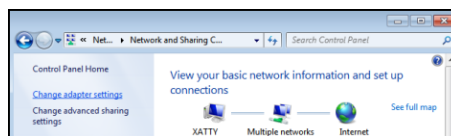
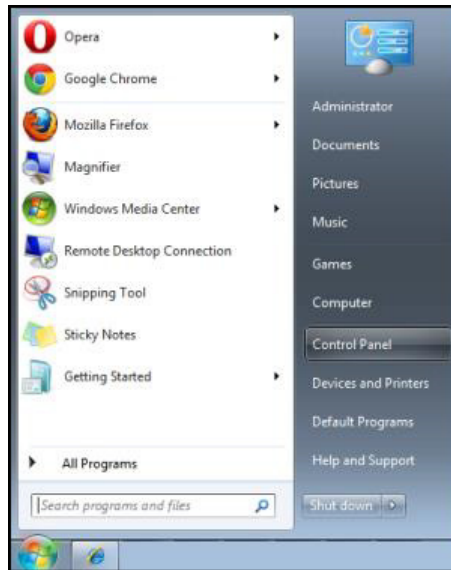

3. Right-click on **Local Area Connection**, and select **Properties**.

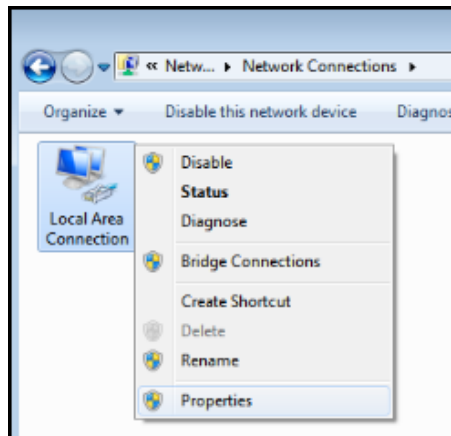

4. In the **Properties** window, select the **Networking** tab, and select **Internet Protocol Version 4 (TCP/IPv4)**.

5. Click **Properties**.

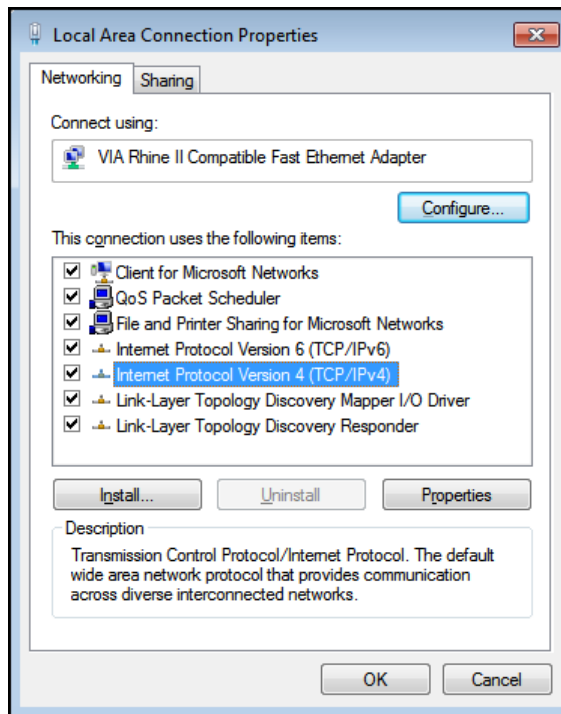

6. Click **Use the following IP address** and fill in the IP address and Subnet mask, then click **OK**.

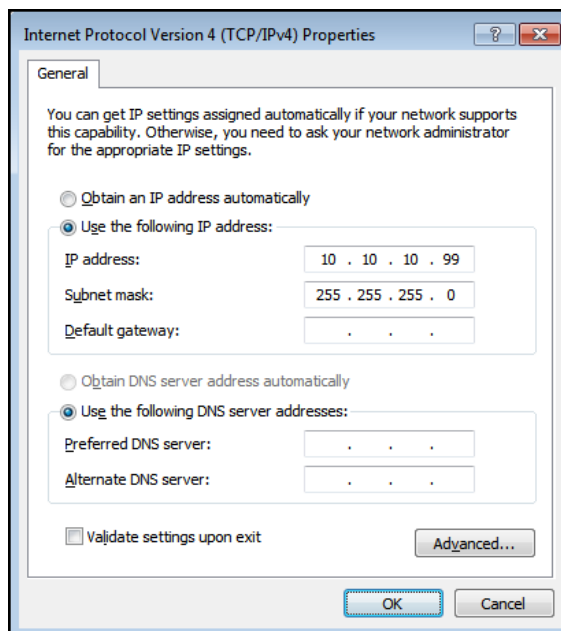

7. Press the **Menu** button on the projector.

8. Select **SETUP** → **Communications** → **LAN**.

9. After getting into **LAN**, input the following:

- DHCP: Off
- IP Address: 10.10.10.10
- Subnet Mask: 255.255.255.0
- Default Gateway: 0.0.0.0

10. Select the **Apply** → **Yes** to confirm the settings, and then wait until finished.

11. Open a web browser (for example, Microsoft Internet Explorer with Adobe Flash Player 9.0 or higher). In the Address bar, input the IP address: 10.10.10.10.

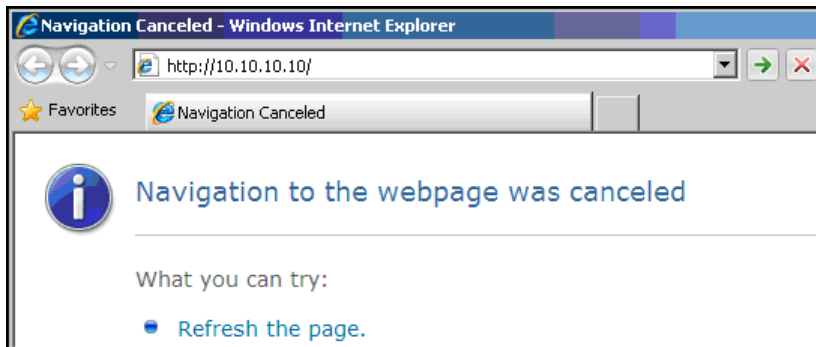

12. Press the **Enter** / ► button.

The projector is setup for remote management. On the first page of the web interface, you can find projector's model name, serial number, power level, power mode, system temperature, network configuration, and firmware version information. To configure projector settings, click on the respective menu on the left side of the interface.

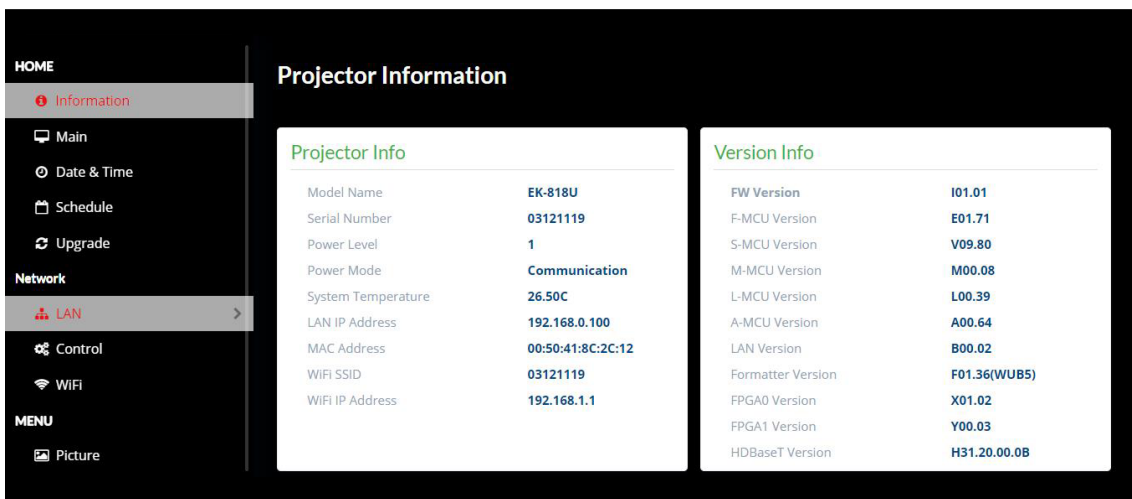

Warping & Blending function

The Warping & Blending application software and its manual can be downloaded from EIKI website.

URL: <https://global.eiki.com>

RS232 by Telnet Function

Besides projector connected to RS232 interface with “Hyper-Terminal” communication by dedicated RS232 command control, there is alternative RS232 command control way, so called “RS232 by TELNET” for LAN/RJ45 interface.

Quick Start-Guide for “RS232 by TELNET”

Check and get the IP-Address on OSD of the projector.

Make sure that laptop/PC can access the web-page of the projector.

Make sure that “Windows Firewall” setting to be disabled in case of “TELNET” function filtering out by laptop/PC.

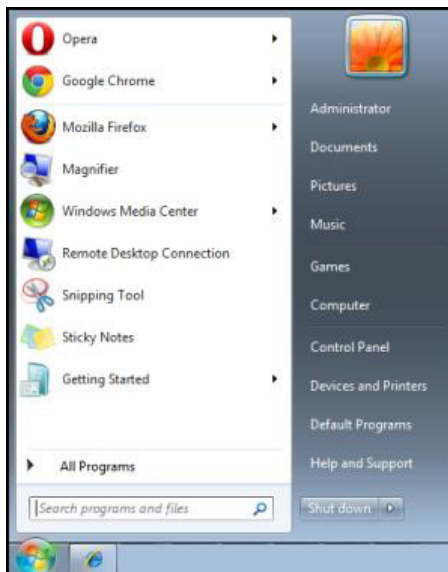

Start → All Programs → Accessories → Command Prompt

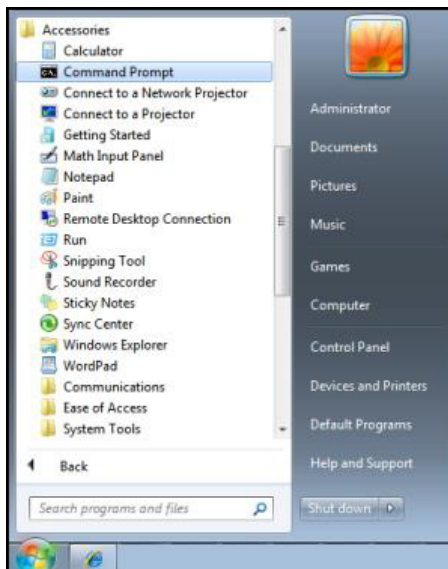

Input the command format like the below:

telnet ttt.xxx.yyy.zzz 3023 (the **Enter** button is pressed)

(**ttt.xxx.yyy.zzz**: IP-Address of the projector)

If Telnet-Connection ready, and user can have RS232 command input, then press the **Enter** button, the RS232 command will be workable.

How to have TELNET enabled in Windows VISTA / 7

By default installation for Windows VISTA, "TELNET" function is not included. But end-user can have it by way of "Turn Windows features On or Off" to be enabled.

1. Open "Control Panel" in Windows VISTA.

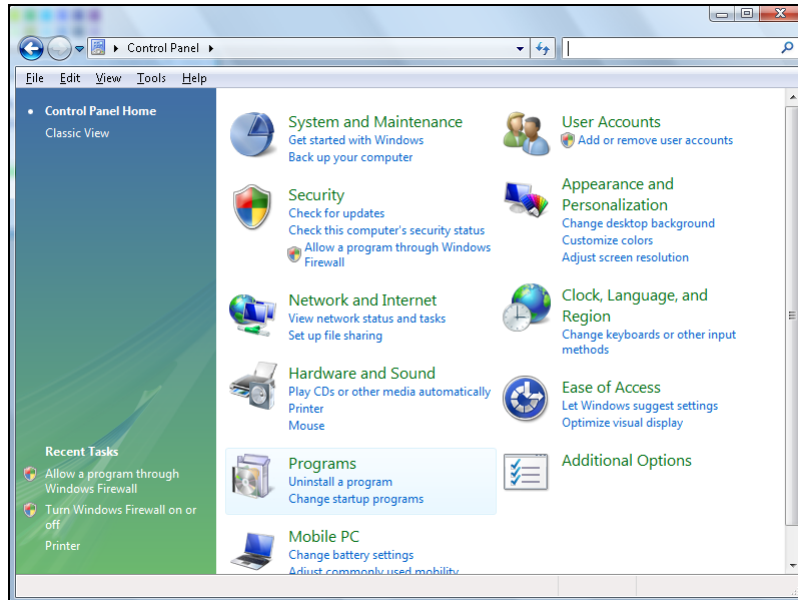

2. Open "Programs".

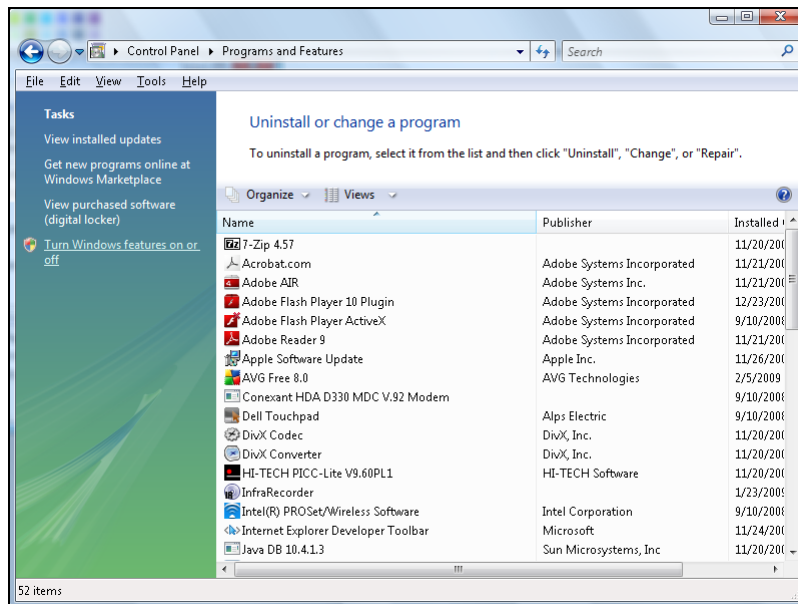

3. Select “Turn Windows features on or off” to open.

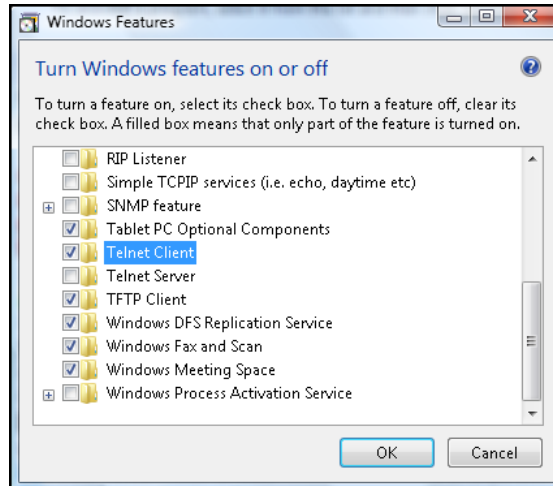

4. Have “Telnet Client” option checked, then click **OK**.

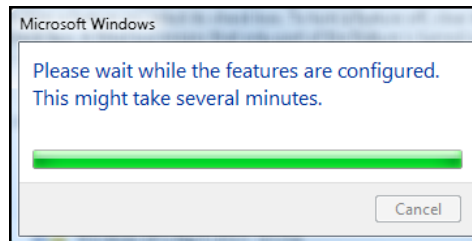

Specsheet for “RS232 by TELNET”:

1. Telnet: TCP
2. Telnet port: 3023
(for more detail, kindly please get contact with the service agent or team)
3. Telnet utility: Windows “TELNET.exe” (console mode)
4. Disconnection for RS232-by-Telnet control normally: Close Windows Telnet utility directly after TELNET connection ready.
5. Limitation 1 for Telnet-Control: there is less than 50 bytes for successive network payload for Telnet-Control application.
Limitation 2 for Telnet-Control: there is less than 31 bytes for one complete RS232 command for Telnet-Control.
Limitation 3 for Telnet-Control: Minimum delay for next RS232 command must be more than 200 (ms).
(*, In Windows built-in “TELNET.exe” utility, pressing the **Enter** button will create a “Carriage-Return” and “New-Line” code.)

Replacing the Projection Lens

Perform the following to replace the projection lens:

1. Center the lens. Use the **Lens H** or **Lens V** button (on the remote control) to adjust the lens at its center position.

Important:

- Ensure that the lens is at or near its center position.
- Attempting to remove the lens when at a large offset may cause damage to the lens assembly.

2. Press “**⏻**” on the built-in keypad or press “**⏻**” on the remote control twice to turn off the projector after cooling down.

3. Remove the lens cover from the lens.

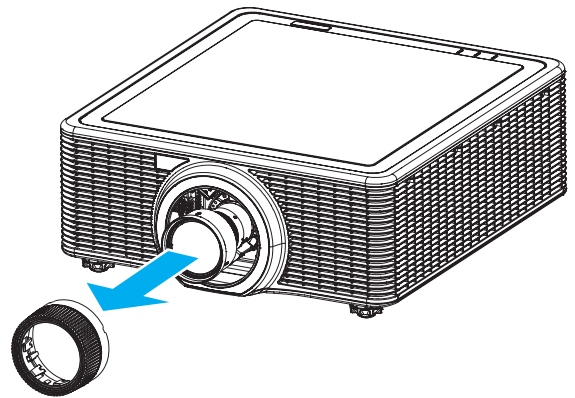

4. Rotate the lens counter-clockwise to disengage it from the lens mount.

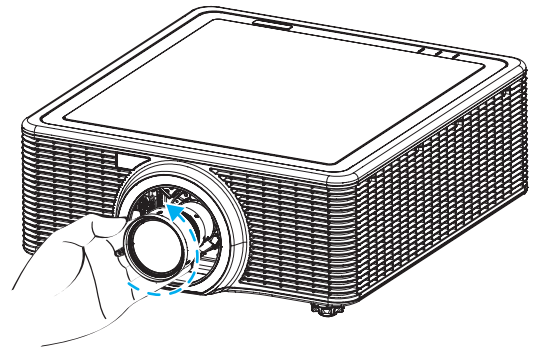

5. Remove the lens out of the lens mount.

6. With the label “TOP” on the lens assembly facing up, install the new lens. See “Installing the Projection Lens” on page 10.

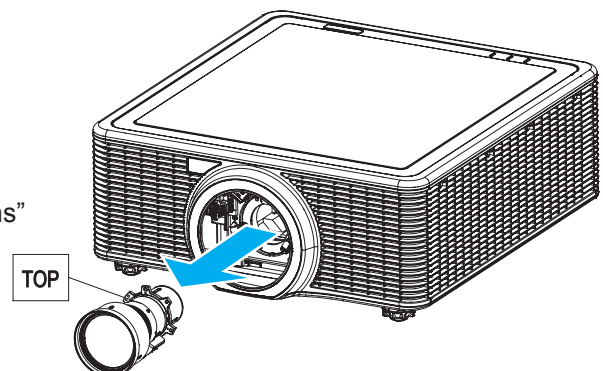

Cleaning the Projector

Cleaning the projector to remove dust and grime will help ensure trouble-free operation.

Warning:

- *Be sure to turn off and unplug the projector at least 30 minutes before cleaning. Failure to do so could result in a severe burn.*
- *Use only a dampened cloth when cleaning. Do not allow water to enter the ventilation openings on the projector.*
- *If a little water gets into the projector interior while cleaning, leave unplugged in a well-ventilated room for several hours before using.*
- *If a lot of water gets into the projector interior when cleaning, have the projector serviced.*

Cleaning the Lens

You can purchase Optical lens cleaner from most camera stores. Refer to the following to clean the projector lens.

1. Apply a little Optical lens cleaner to a clean soft cloth. (Do not apply the cleaner directly to the lens.)
2. Lightly wipe the lens in a circular motion.

Caution:

- *Do not use abrasive cleaners or solvents.*
- *To prevent discoloration or fading, avoid getting cleaner on the projector case.*

Cleaning the Case

Refer to the following to clean the projector case.

1. Wipe off dust with a clean dampened cloth.
2. Moisten the cloth with warm water and mild detergent (such as used to wash dishes), and then wipe the case.
3. Rinse all detergent from the cloth and wipe the projector again.

Caution:

To prevent discoloration or fading of the case, do not use abrasive alcohol-based cleaners.

Using the Kensington® Lock

If you are concerned about security, attach the projector to a permanent object with the Kensington slot and a security cable.

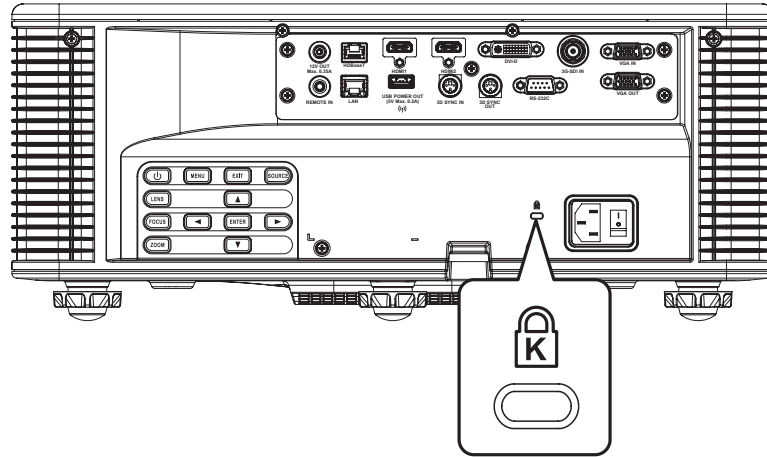

Note:

Contact your vendor for details on purchasing a suitable Kensington security cable.

The security lock corresponds to Kensington's MicroSaver Security System. If you have any comment, contact: Kensington, 2853 Campus Drive, San Mateo, CA 94403, U.S.A. Tel: 800-535-4242, <http://www.Kensington.com>.

Common Problems and Solutions

These guidelines provide tips to deal with problems you may encounter while using the projector. If the problem remains unsolved, contact your dealer for assistance.

Often after time spent troubleshooting, the problem is traced to something as simple as a loose connection. Check the following before proceeding to the problem-specific solutions.

- Use some other electrical device to confirm that the electrical outlet is working.
- Ensure the projector is turned on.
- Ensure all connections are securely attached.
- Ensure the attached device is turned on.
- Ensure a connected PC is not in suspending mode.
- Ensure a connected notebook computer is configured for an external display. (This is usually done by pressing an Fn-key combination on the notebook.)

Tips for Troubleshooting

- In each problem-specific section, try the steps in the order suggested. This may help you to solve the problem more quickly.
- Try to pin point the problem and thus avoid replacing non-defective parts. For example, if you replace batteries and the problem remains, put the original batteries back and go to the next step.
- Keep a record of the steps you take when troubleshooting: The information may be useful when calling for technical support or for passing on to service personnel.

LED Error Messages

The LED status indicators are located on the top of the projector. Each LED is defined below.

MESSAGE	LIGHT LED			STATUS LED			AV MUTE LED	
	GREEN	ORANGE	RED	GREEN	ORANGE	RED	GREEN	ORANGE
Standby State(*)	-	-	-	Flashing	-	-	-	-
Power on (Warm up)	-	-	-	-	Flashing	-	-	-
Power on & Laser diode on	Steady	-	-	Steady	-	-	Steady	-
Power off (Cooling down)	-	-	-	-	Flashing	-	-	-
AV mute is off (Image is displayed)	Steady	-	-	Steady	-	-	Steady	-
AV mute is on (Image is black)	Steady	-	-	Steady	-	-	-	Steady
Projector communication	Steady	-	-	Flashing	-	-	Steady	-
Firmware upgrade	-	-	-	Flashing	Flashing	-	-	-
Error (Over temperature)	-	-	-	-	-	Steady	-	-
Error (Fan failure)	-	-	-	-	-	Flashing	-	-

Image Problems

Problem: No image appears on the screen

1. Verify the settings on your notebook or desktop PC.
2. Turn off all equipment and power on again in the correct order.

Problem: The image is blurred

1. Press the **Focus** button to adjust the focus on the projector.
2. Press the **Auto** button on the remote control to automatically optimize image.
3. Ensure the projector-to-screen distance is within the specified range.
4. Check that the projector lens is clean.

Problem: The image is wider at the top or bottom (trapezoid effect)

1. Position the projector so it is as perpendicular to the screen as possible.
2. Press the **Keystone H** or **Keystone V** button on the remote control to correct the problem.

Problem: The image is reversed

Check the **Rear Projection** on the **Setup** menu of the OSD.

Problem: The image is streaked

1. Set the **Phase** setting on the **Picture** menu of the OSD to the default settings.
2. Ensure the problem is not caused by a connected PC's video card, connect to another computer.

Problem: The image is flat with no contrast

Adjust the **Contrast** setting on the **Picture** menu of the OSD.

Problem: The color of the projected image does not match the source image

Adjust the **Color Temperature** and **Gamma** settings on the **Picture > Advanced** menu of the OSD.

Laser Diode Problems

Problem: There is no light from the projector

1. Check that the power cable is securely connected.
2. Ensure the power source is good by testing with another electrical device.
3. Restart the projector in the correct order and check that the Light LED is green.

Problem: The laser diode goes off

1. Power surges can cause the laser diode to turn off. Re-plug power cord. If the Light LED is in orange, this indicates that the laser diode time has expired. Then press “

Remote Control Problems

Problem: The projector does not respond to the remote control

1. Direct the remote control towards remote sensor on the projector.
2. Ensure the path between remote and sensor is not obstructed.
3. Turn off any fluorescent lights in the room.
4. Make sure that the batteries are installed with the correct polarity.
5. Replace the batteries.
6. Turn off other Infrared-enabled devices in the vicinity.
7. Have the remote control serviced.

Having the Projector Serviced

If you are unable to solve the problem, you should have the projector serviced. Pack the projector in the original carton. Include a description of the problem and a checklist of the steps you took when trying to fix the problem. The information may be useful to service personnel. For servicing, return the projector to the place you purchased it.

HDMI Q & A

Q. What is the difference between a “Standard” HDMI cable and a “High-Speed” HDMI cable?

Recently, HDMI Licensing, LLC announced that cables would be tested as Standard or High-Speed cables.

- Standard (or “category 1”) HDMI cables have been tested to perform at speeds of 75Mhz or up to 2.25Gbps, which is the equivalent of a 720p/1080i signal.
- High Speed (or “category 2”) HDMI cables have been tested to perform at speeds of 340Mhz or up to 10.2Gbps, which is the highest bandwidth currently available over an HDMI cable and can successfully handle 1080p signals including those at increased color depths and/or increased refresh rates from the Source. High-Speed cables are also able to accommodate higher resolution displays, such as WQXGA cinema monitors (resolution of 2560 x 1600).

Q. How do I run HDMI cables longer than 10 meters?

There are many HDMI Adopters working on HDMI solutions that extend a cable's effective distance from the typical 10 meter range to much longer lengths. These companies manufacture a variety of solutions that include active cables (active electronics built into cables that boost and extend the cable's signal), repeaters, amplifiers as well as CAT5/6 and fiber solutions.

Q. How can I tell if a cable is an HDMI certified cable?

All HDMI products are required to be certified by the manufacturer as part of the HDMI Compliance Test Specification. However, there may be instances where cables bearing the HDMI logo are available but have not been properly tested. HDMI Licensing, LLC actively investigates these instances to ensure that the HDMI trademark is properly used in the market. We recommend that consumers buy their cables from a reputable source and a company that is trusted.

For more detail information check <http://www.hdmi.org/learningcenter/faq.aspx#49>.

Specifications

ITEM	DESCRIPTION	
Display type	0.67" WUXGA DMD	
Resolution	WUXGA (1920 x 1200)	
Zoom/focus	Power zoom and focus	
Zoom ratio	Depend on Lens	
Keystone correction	Vertical: +/- 20 degrees, Horizontal: +/- 20 degrees	
Projection methods	Front, Rear, Desktop/Ceiling (Rear, Front)	
Data compatibility	VGA, SVGA, XGA, WXGA, SXGA, SXGA+, UXGA, WUXGA, HD, UHD, Mac	
Video compatibility	4K/2K, 1080 i/p, 720p, 576 i/p, 480 i/p	
H-Sync	15, 31~135KHz	
V-Sync	24 ~ 30Hz, 47 ~ 120Hz	
Safety Certification	UL/cUL, FCC, CE, CB, CCC (China), KC/KCC	
Operation temperature	5° ~ 40°C	
Dimensions (W x H x D)	484 x 181 x 509 mm (without lens and elevators)	
Weight	17.7 kg (EK-812U model) 18.0 kg (EK-818U model)	
AC Input	AC 100 ~ 240V @50/60 Hz	
Power Consumption	EK-812U: - 290W (ECO brightness mode) ; 585W (Normal brightness mode)	
	EK-818U: - 315W (ECO brightness mode) ; 650W (Normal brightness mode)	
Laser Diode Power	EK-812U 95W+95W @3A EK-818U 115W+95W @3A	
Laser Diode Life	20,000 Hours at Normal Mode	
Input Terminals	2 x HDMI (version2.0) (with locking screw) 1 x DVI-D (only support digital signal) 1 x VGA In (D-Sub 15pin) (Computer In or Component)	1 x HDBaseT 1 x 3D SYNC In 1 x 3G SDI
Output Terminals	1 x VGA Out (Support VGA loops through to monitor) (Monitor Out) 1 x 3D SYNC Out 1 x DC12V Out	
Control Terminals	1 x RS232 (D-sub 9 pin) (PC Control) 1 x Wired In (3.5mm phone jack) (Remote In)	1 x RJ45 (LAN) 1 x USB (WiFi dongle support)
Security	Kensington lock Security bar	

Note:

For questions regarding product specifications, please contact your local distributor.

Projection Distance vs. Projection Size

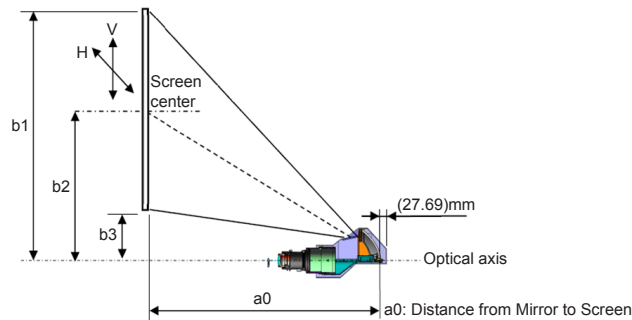

Projection Distance and Size Table

PLATFORM			WUXGA (16:10)																					
DMD			0.67"																					
PROJECTION LENS			A16		A01		A06		A03		A13		A15											
			ULTRA SHORT THROW		WIDE ZOOM		STANDARD		LONG ZOOM		ULTRA-LONG ZOOM		SHORT THROW											
THROW RATIO			0.361 (120")		0.95-1.22		1.22-1.52		1.52-2.92		2.90-5.50		0.75-0.95											
ZOOM RATIO			N/A		1.28X		1.25X		1.9X		1.9X		1.26X											
PROJECTION DISTANCE (M) (MIN/MAX)			0.96-3.01M		1.01-7.98M		1.29-9.93M		1.61-19.00M		3.18-34.77M		0.79-6.21M											
PROJECTION SCREEN SIZE			PROJECTION DISTANCE (M)																					
THROW RATIO SPEC.			0.361 (120")		0.95		1.22		1.22		1.52		1.52		2.92		2.9		5.5		0.75		0.95	
DIAGONAL (INCH)	HEIGHT (M)	WIDTH (M)	(M)	MIN (M)	MAX (M)	MIN (M)	MAX (M)	MIN (M)	MAX (M)	MIN (M)	MAX (M)	MIN (M)	MAX (M)	MIN (M)	MAX (M)	MIN (M)	MAX (M)							
50	0.67	1.08	NA	1.01	1.31	1.29	1.62	1.61	3.12	3.18	5.89	0.79	1.01											
60	0.81	1.29	NA	1.22	1.57	1.56	1.95	1.94	3.76	3.78	7.05	0.96	1.22											
70	0.94	1.51	NA	1.43	1.84	1.82	2.29	2.27	4.39	4.39	8.20	1.12	1.43											
80	1.08	1.72	NA	1.63	2.11	2.09	2.62	2.60	5.03	5.00	9.36	1.28	1.64											
90	1.21	1.94	NA	1.84	2.38	2.35	2.95	2.94	5.66	5.61	10.51	1.45	1.85											
100	1.35	2.15	NA	2.05	2.64	2.62	3.28	3.27	6.30	6.21	11.67	1.61	2.05											
110	1.48	2.37	NA	2.26	2.91	2.89	3.62	3.60	6.93	6.82	12.82	1.78	2.26											
120	1.62	2.58	0.96	2.47	3.18	3.15	3.95	3.94	7.57	7.43	13.98	1.94	2.47											
130	1.75	2.80	1.04	2.67	3.44	3.42	4.28	4.27	8.20	8.04	15.13	2.10	2.68											
140	1.88	3.02	1.11	2.88	3.71	3.69	4.61	4.60	8.84	8.65	16.29	2.27	2.89											
150	2.02	3.23	1.18	3.09	3.98	3.95	4.95	4.94	9.47	9.25	17.44	2.43	3.09											
160	2.15	3.45	1.26	3.30	4.24	4.22	5.28	5.27	10.11	9.86	18.60	2.60	3.30											
170	2.29	3.66	1.33	3.51	4.51	4.48	5.61	5.60	10.74	10.47	19.75	2.76	3.51											
180	2.42	3.88	1.40	3.72	4.78	4.75	5.94	5.93	11.38	11.08	20.91	2.92	3.72											
190	2.56	4.09	1.48	3.92	5.05	5.02	6.27	6.27	12.01	11.69	22.06	3.09	3.93											
200	2.69	4.31	1.55	4.13	5.31	5.28	6.61	6.60	12.65	12.29	23.22	3.25	4.13											
250	3.37	5.38	1.91	5.17	6.65	6.61	8.27	8.27	15.82	15.33	28.99	4.07	5.17											
300	4.04	6.46	2.28	6.21	7.98	7.95	9.93	9.93	19.00	18.37	34.77	4.89	6.21											
350	4.71	7.54	2.65	NA																				

Note:

- The values in the tables are approximate and may be slightly different from the actual measurements.
- In case of ceiling mount, it is necessary to match at the spot.

Timing Mode Table

SIGNAL TYPE	RESOLUTION	FRAME RATE (Hz)	VGA	HDMI1	HDMI2	DVI	3G-SDI	HDBASET
PC	640x480	60	V	V	V	V	—	V
	640x480	72	V	V	V	V	—	V
	640x480	75	V	V	V	V	—	V
	640x480	85	V	V	V	V	—	V
	640x480	66.6	—	V	V	V	—	V
	720x400	70	V	V	V	V	—	V
	800x600	60	V	V	V	V	—	V
	800x600	72	V	V	V	V	—	V
	800x600	75	V	V	V	V	—	V
	800x600	85	V	V	V	V	—	V
	800x600	120	V	V	V	V	—	V
	832x624	75	V	V	V	V	—	V
	848x480	50	—	V	V	V	—	V
	848x480	60	—	V	V	V	—	V
	848x480	75	—	V	V	V	—	V
	848x480	85	—	V	V	V	—	V
	1024x768	60	V	V	V	V	—	V
	1024x768	75	V	V	V	V	—	V
	1024x768	85	V	V	V	V	—	V
	1024x768	120	V	V	V	V	—	V
	1152x720	50	—	V	V	V	—	V
	1152x720	60	—	V	V	V	—	V
	1152x720	75	—	V	V	V	—	V
	1152x720	85	—	V	V	V	—	V
	1152x864	60	V	V	V	V	—	V
	1152x864	70	V	V	V	V	—	V
	1152x864	75	V	V	V	V	—	V
	1152x864	85	V	V	V	V	—	V
	1152x870	75	—	V	V	V	—	V
	1280x720	50	—	V	V	V	—	V
	1280x720	60	V	V	V	V	—	V
	1280x720	75	V	V	V	V	—	V
	1280x720	85	V	V	V	V	—	V
	1280x720	120	V	V	V	V	—	V
	1280x768	60	V	V	V	V	—	V
	1280x768	75	V	V	V	V	—	V
	1280x768	85	V	V	V	V	—	V
	1280x800	50	V	V	V	V	—	V
	1280x800	60	V	V	V	V	—	V
	1280x800	75	V	V	V	V	—	V
1280x800	85	V	V	V	V	—	V	
1280x960	50	—	V	V	V	—	V	

SIGNAL TYPE	RESOLUTION	FRAME RATE (Hz)	VGA	HDMI1	HDMI2	DVI	3G-SDI	HDBASET
PC	1280x960	60	V	V	V	V	—	V
	1280x960	75	V	V	V	V	—	V
	1280x960	85	V	V	V	V	—	V
	1280x1024	50	—	V	V	V	—	V
	1280x1024	60	V	V	V	V	—	V
	1280x1024	75	V	V	V	V	—	V
	1280x1024	85	V	V	V	V	—	V
	1360x768	50	—	V	V	V	—	V
	1360x768	60	—	V	V	V	—	V
	1360x768	75	—	V	V	V	—	V
	1360x768	85	—	V	V	V	—	V
	1368x768	60	V	V	V	V	—	V
	1400x1050	50	—	V	V	V	—	V
	1400x1050	60	—	V	V	V	—	V
	1400x1050	75	V	V	V	V	—	V
	1440x900	60	V	V	V	V	—	V
	1440x900	75	—	V	V	V	—	V
	1600x900	60	—	V	V	V	—	V
	1600x1200	60	V	V	V	V	—	V
	1680x1050	60	V	V	V	V	—	V
	1920X1080	50	—	V	V	V	—	V
	1920X1080	60	V	V	V	V	—	V
	1920X1200RB	60	V	V	V	V	—	V
	1920X1200RB	50	V	V	V	V	—	V
NTSC	NTSC (M, 4.43)	60	—	—	—	—	—	—
PAL	PAL (B,G,H,I)	50	—	—	—	—	—	—
	PAL (N)	50	—	—	—	—	—	—
	PAL (M)	60	—	—	—	—	—	—
SECAM	SECAM (M)	50	—	—	—	—	—	
SDTV	480i	60	V	V	V	V	—	V
	576i	50	V	V	V	V	—	V
EDTV	480p	60	V	V	V	V	—	V
	576p	50	V	V	V	V	—	V
HDTV	1080i	25	V	V	V	V	—	V
	1080i	29	V	V	V	V	—	V
	1080i	30	V	V	V	V	—	V
	720p	50	V	V	V	V	—	V
	720p	59	V	V	V	V	—	V
	720p	60	V	V	V	V	—	V
	1080p	23	V	V	V	V	—	V
	1080p	24	V	V	V	V	—	V
	1080p	25	V	V	V	V	—	V
1080p	29	V	V	V	V	—	V	

SIGNAL TYPE	RESOLUTION	FRAME RATE (Hz)	VGA	HDMI1	HDMI2	DVI	3G-SDI	HDBASET	
HDTV	1080p	30	V	V	V	V	—	V	
	1080p	50	V	V	V	V	—	V	
	1080p	59	V	V	V	V	—	V	
	1080p	60	V	V	V	V	—	V	
Mandatory 3D	Frame Packing 1080p	24	—	V	V	V	—	V	
	Frame Packing 720p	50	—	V	V	V	—	V	
	Frame Packing 720p	60	—	V	V	V	—	V	
	Side by Side 1080i	50	—	V	V	V	—	V	
	Side by Side 1080i	60	—	V	V	V	—	V	
	Top and Bottom 720p	50	—	V	V	V	—	V	
	Top and Bottom 720p	60	—	V	V	V	—	V	
Frame sequential 3D	800x600	120	—	V	V	V	—	V	
	1024x768	120	—	V	V	V	—	V	
	1280x720	120	—	V	V	V	—	V	
	1080P	120	—	V	V	V	—	V	
	1080P	60	—	V	V	V	—	V	
	WUXGA	60	—	V	V	V	—	V	
SD-SDI	480i YcbCr422 10bit	59.94	—	—	—	—	V	—	
	576i YcbCr422 10bit	50	—	—	—	—	V	—	
HD-SDI	720p YcbCr422 10bit	50	—	—	—	—	V	—	
		59.94	—	—	—	—	V	—	
		60	—	—	—	—	V	—	
	1080i YcbCr422 10bit	50	—	—	—	—	—	V	—
		59.94	—	—	—	—	—	V	—
		60	—	—	—	—	—	V	—
	1080p YcbCr422 10bit	23.98	—	—	—	—	—	V	—
		24	—	—	—	—	—	V	—
		25	—	—	—	—	—	V	—
		29.97	—	—	—	—	—	V	—
		30	—	—	—	—	—	V	—
	1080sF YcbCr422 10bit	25	—	—	—	—	—	V	—
29.97		—	—	—	—	—	V	—	
30		—	—	—	—	—	V	—	

SIGNAL TYPE	RESOLUTION	FRAME RATE (Hz)	VGA	HDMI1	HDMI2	DVI	3G-SDI	HDBASET
3GA-SDI	1080p YcbCr422 10bit	50	—	—	—	—	V	—
		59.94	—	—	—	—	V	—
		60	—	—	—	—	V	—
3GB-SDI	1080p YcbCr422 10bit With 352M Payload ID	50	—	—	—	—	V	—
		59.94	—	—	—	—	V	—
		60	—	—	—	—	V	—
4K	3840x2160	23.976	—	V	V	V	—	V
		24.000	—	V	V	V	—	V
		25.000	—	V	V	V	—	V
		29.970	—	V	V	V	—	V
		30.000	—	V	V	V	—	V
		50.000	—	V	V	—	—	—
		59.940	—	V	V	—	—	—
		60.000	—	V	V	—	—	—
	4096x2160	23.976	—	V	V	V	—	V
		24.000	—	V	V	V	—	V
		25.000	—	V	V	V	—	V
		29.970	—	V	V	V	—	V
		30.000	—	V	V	V	—	V
		50.000	—	V	V	—	—	—
		59.940	—	V	V	—	—	—
60.000	—	V	V	—	—	—		

V : Frequency supported

— : Frequency not supported

Projector Dimensions

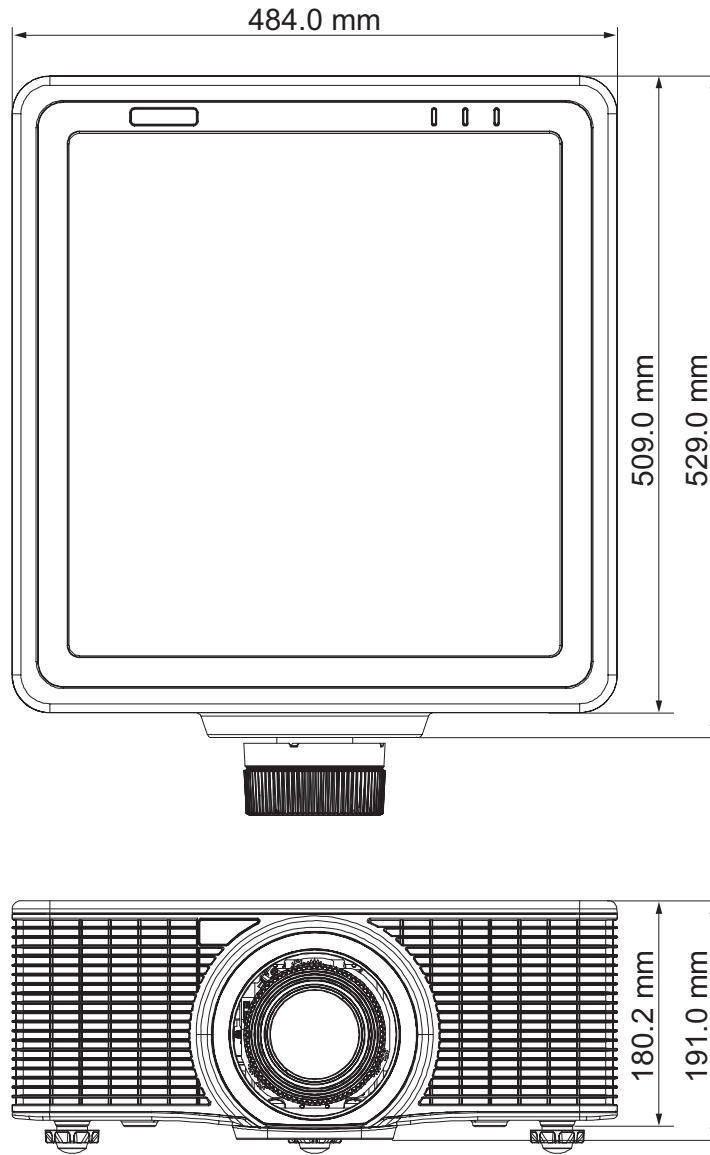

REGULATORY COMPLIANCE

FCC Warning

This equipment has been tested and found to comply with the limits for a Class A digital device pursuant to Part 15 of the FCC Rules. These limits are designed to provide reasonable protection against harmful interference when the equipment is operated in a commercial environment.

This equipment generates, uses, and can radiate radio frequency energy and, if not installed and used in accordance with the instruction manual, may cause harmful interference to radio communications. Operation of this equipment in a residential area is likely to cause harmful interference in which case the user will be required to correct the interference at his/her own expense.

Changes or modifications not expressly approved by the parties responsible for compliance could void the user's authority to operate the equipment.

Canada

This class A digital apparatus complies with Canadian ICES-003.

Safety Certifications

UL/cUL, FCC, CE, CB, CCC (China), KC/KCC

EIKI

U.S.A.

EIKI International, Inc.
30251 Esperanza
Rancho Santa Margarita
CA 92688-2132
U.S.A.
Tel: +1 800-242-3454 +1 949-457-0200
Fax: +1 800-457-3454 +1 949-457-7878
E-Mail: usa@eiki.com

Deutschland & Österreich

EIKI Deutschland GmbH
Am Frauwald 12
65510 Idstein
Deutschland
Tel: +49 6126-9371-0
Fax: +49 6126-9371-11
E-Mail: info@eiki.de

South East Asia

EIKI Industrial (M) Sdn Bhd
No. 11, Nouvelle Industrial Park,
Lorong Teknologi B, Taman Sains
Selangor 1, Kota Damansara PJU5,
47810 Petaling Jaya, Selangor Darul Ehsan,
Malaysia
Tel: +60 3-6157-9330
Fax: +60 3-6157-1320
E-Mail: sales@eiki.my

China

EIKI (Shanghai) Co., Ltd.
LAKESIDE OASIS MIDDLE RING
BUSINESS CENTRE
Block 1, Room 606,
1628, Jin Sha Jiang Road
Shanghai, 200333
CHINA
Tel: +86 21-3251-3993
Service Hot line: +86 21-3251-3995
Fax: +86 21-3251-3997
E-mail: info@eiki-china.com

Canada

EIKI CANADA - Eiki International, Inc.
9170 County Road 93, Suite 304,
Midland, ON, L4R 4K4, Canada
Tel: +1 800-563-3454
+1 705-527-4084
E-Mail: canada@eiki.com

Eastern Europe

EIKI CZECH SPOL. S.R.O.
Branicka 416/237
140 00 Praha 4
Czech Republic
Tel: +420 241-410-928
+420 241-403-095
Fax: +420 241-409-435
E-Mail: info@eiki.cz

Oceania

EIKI AUSTRALIA PTY LTD
Level 5, 11 Queens Road,
Melbourne, Victoria 3004
Tel: +61 03-8530-7048
Fax: +61 03-9820-5834
E-Mail: sales@eiki.net.au

Japan & Worldwide

EIKI Industrial Company Limited.
6-23 Teramoto, Itami-shi, Hyogo,
664-0026 JAPAN
Tel: +81 72-782-7492
Fax: +81 72-781-5435

WorldWide Website <https://global.eiki.com>